

S.A. POLICE DEPARTMENT

EMERGENCY FIRE SERVICES/CIVIL
DEFENCE LIGHT RESCUE COURSE

DRILL MANUAL

Name

Bed Noalard 54 WINDY RD
Elizabeth ELIZABETH N. H.
E.F.S.

S.A. POLICE DEPARTMENT
EMERGENCY FIRE SERVICES
 Police Barracks
THEBARTON

E.F.S./CIVIL DEFENCE

LIGHT RESCUE - TRAINING COURSE.

S Y L L A B U S

<u>DATE.</u>	<u>PARADE</u>	<u>HOURS</u>	<u>PROGRAMME</u>	<u>INSTRUCTOR.</u>
WED 13/7/66	1.	2000- 2230	Roll Call, Opening Address. LECTURES:- Role of EFS in Civil Defence. Rescue Service, Manpack and Personal Equipment. FILM:- Five Stages of Rescue.	D/O ROSEWARNE. F.L. KERR MBE. M.I. Fire E. F.C.C. J.L. FITZGERALD.
SUN. 17/7/66	2.	0900- 1600	Parade, Roll Call, Squad Drill. Ropes and Knots. Hand Rescue Methods Blanket Lift. Webbing Bands. Chair Knot Demonstration. Blanketing, Lashing and Handling a Stretcher. 2 and 4 Point Horizontal Suspension. 2 point vertical suspension. Handling and testing of ladders. 2 and 3 man Drills using 35 ft Extension ladder.	S/O SIMMONS
WED. 20/7/66	3.	2000- 2230	Parade, Roll Call, Squad Drill. Ladder slide and Ladder Hinge.	S/O SIMMONS.
WED. 27/7/66	4.	2000- 2230	Parade, Roll Call, Squad Drill. Gyn, Porto Power, Tirfor, Remote Breathing Apparatus.	S/O SIMMONS.
SUN. 31/7/66	5.	0900- 1600	Parade, Roll Call, Squad Drill. Revision and Exercises.	S/O SIMMONS
WED. 3/8/66	6.	2000- 2230	Parade, Roll Call. Graduation Exercises. Presentation of Certificates.	S/O SIMMONS.

-----oOo-----

S.A. POLICE DEPARTMENT
EMERGENCY FIRE SERVICES
Police Barracks
THEBARTONFIVE STAGES OF RESCUE AND RECONNAISSANCEOBJECT

The object of this Circular is to outline methods of the Five Stages of Rescue and Reconnaissance.

RECONNAISSANCE.

Good reconnaissance ('recce') is one of the secrets of success in all rescue work, either at small or large incidents. Time spent in this way is seldom wasted and invariably results in a great economy in the amount of work required to extricate and give first-aid attention to trapped casualties. A careful recce will also result in a proper priority of treatment for these casualties who are not buried or trapped.

Rescue recce is in effect an attempt to arrive at an accurate assessment of the number and whereabouts of trapped casualties, with a view to deciding the best method to adopt for their release. This is done by piecing together all available information and reports given through the Warden and combining them with data which can be obtained by direct observation, such as listening for any sounds which might be made by casualties, carefully observing the way in which a building has collapsed and whether special use can be made of any particular debris formation, such as voids, etc.

There are thus two distinct parts or sides to the job making a recce: (a) Information (b) Observation.

INFORMATION.

Normally, most of the necessary information concerning reports as to the whereabouts of casualties will be collected and supplied to the Rescue Leader by the Warden, but even where this is done there will still be many points of detail about which the Leader will want to ask questions relating both to the casualties and the layout and construction of the building. The best practice is for the Warden to try to secure reliable 'witnesses' to help the Leader, rather than do all the interrogation himself and then have to pass it on to the Leader.

In collecting information of any kind the first thing is to check the authority and reliability of the person giving information, remembering always that he or she may be in an excited or distressed state and may give entirely wrong information. A very clear line should also be drawn between what is fact and what is opinion or hearsay. It is sometimes found that what is given as absolute fact will turn out on further questioning to be no more than opinion built up on what has been heard from others. Hearsay and indefinite ideas should be so far as possible traced back through one person and another to their source, because in all probability there will be some element of fact to be found in this way. All information should be verified in as many ways as possible, and here again a careful distinction between fact and opinion should always be made. As an example, it may be reported by some witnesses that one old woman has already been removed from the building and taken to hospital. This may be confirmed by others. What they really saw, however, was a figure wrapped in bed clothes being helped over the debris. Whether this person was a man or woman may have a very important bearing upon the recce as a whole, and the proper way to verify this kind of information is to send someone actually to see and, if possible, speak with the witnesses in question. In their efforts to be helpful, untrained persons often have an unconscious habit of confusing opinion with fact, especially on matters of detail.

The assistance of Police Officers and others who have received special training in how to collect and verify information should be sought by the Rescue Leader whenever available, so as to leave himself free to carry out the observation side of recce, a job which he must do himself.

OBSERVATION.

Apart from having a general look over the whole site which should be the Leader's first task, a great deal of very useful information can usually be obtained from a careful observation of how a building has collapsed. This should be done in the light of any information available concerning probable casualties. First, some attempt should be made to locate and identify the parts of the building, the main entrance, staircase, kitchen, etc., and especially those parts of the building mentioned in the word picture given by the Warden. This will enable a rough idea to be obtained as to where casualties might be found in relation to the various parts of the damaged structure at the time of the occurrence. This process of translating information with reference to the undamaged building into terms of the damaged building is the most difficult and certainly one of the most important parts of technical rescue recce, for it is only from this that any kind of effective plan of action can be built up.

The art of rescue lies in being able to identify and exploit to the maximum all debris formations, such as voids, etc., which can be used to facilitate access to the casualty, once the whereabouts of the casualty has been fixed by information and inference. To be able to do this successfully will depend to a great extent upon careful observation on the part of the Leader.

The secret of efficient working is that every man should do the job for which he is best suited and that he should work to his full capacity. This is possible only if all Leaders fully appreciate the capabilities of their men and co-operate fully to use each man to the best possible advantage.

FIVE STAGES OF RESCUE.

The rescue problem at the scene of an incident is always approached by stages, of which there are five, known as the Five Stages of Rescue. These stages do not, in all cases, have to be strictly adhered to, but any deviation made is due only to unusual circumstances in the particular incident concerned.

Stage 1: Reconnaissance and Dealing with Surface Casualties.

It will be appreciated that in every plan of action reconnaissance (i.e. Information and Observation) is an essential preliminary to any stage of rescue. There must be a general survey to ensure that surface casualties have been dealt with by Wardens or others who have been trained in basic rescue and first aid, and who may be working in teams. If this has not been done, the party must make a recce, working from the perimeter and giving priority to those in immediate danger. Some of these surface casualties may be only slightly injured, or dazed and suffering from shock. At the same time the leader makes a quick but thorough examination of the site, assessing complicated factors such as coal gas, war gases, radioactivity, flooding, dangers from overhanging walls, etc. and obtains and records all possible information on the believed whereabouts of other casualties.

Stage 2: Searching Slightly Damaged Buildings and Immediate Rescue.

Slightly damaged buildings must be searched to ensure that all casualties have been dealt with by Wardens or others, and also to recover those who are lightly trapped. Contact should be maintained with those who can be seen or heard or whose whereabouts can be definitely ascertained.

In carrying out this stage, a speedy but careful examination of the damaged structures and debris is needed, in order to determine the best and safest approach.

Stage 3: Exploration of likely Survival Points.

All places must be searched where persons could be trapped or injured and remain alive. Strong or sheltered parts of buildings which are likely to have withstood damage (e.g. shelters, staircase cupboards, basements) should not be overlooked, even though there is no definite information that anyone is trapped there.

Stage 4: Further Exploration and Selected Debris Removal.

If persons are still missing, and places where they may be buried have been explored, the search should be continued even if the chance of their remaining alive is remote or non-existent. This will involve removing debris from selected places where casualties are presumed to be, having regard to the information available at the site coupled with a careful study of the way in which buildings have collapsed.

In cases where the Party Leader is confronted with a heap of rubble, bricks and debris, it may be possible to determine the whereabouts of conscious casualties by introducing a 'Silence Period' of calling and listening for replies or tappings, indicating their positions. Where casualties may be unconscious, or unable to make themselves heard, their position may be ascertained by the use of dogs trained in rescue work.

Stage 5: General Debris Clearance.

Where it is still impossible to account for all missing persons, it may be necessary to strip the site of debris methodically by cutting lanes into the rubble, or by piecemeal removal of debris, until missing bodies, or parts of bodies, are recovered. During this operation the various types of debris must be segregated.

Whether or not information as to the whereabouts of casualties is available from Wardens, Police or members of the general public, the first four stages as set out above should always be completed. Where persons are still missing, Stage 5 must also be carried out before the rescue operations are finally discontinued.

Where operations are prolonged relief parties will be called and the incoming Party Leader must be given a report by the outgoing Party Leader of progress. A normal time for a party to work continuously before relief is about four hours.

CONCLUSION.

The value of reconnaissance can never be stressed sufficiently. It has been the means of saving countless lives in rescue work and will continue to be so, no matter the type of rescue problem involved. Similarly, experience has shown the need for a systematic approach to the problem based on the five stages outlined.

S.A. POLICE DEPARTMENT
EMERGENCY FIRE SERVICES
Police Barracks
THEBARTONMANPACK AND PERSONAL EQUIPMENTOBJECT

1. To explain the scales of personal, manpack and vehicle equipment for both light and heavy elements of Rescue.

DESCRIPTION OF MANPACK AND EQUIPMENT

2. The webbing, adapted from standard service equipment, is utilised to support certain items of equipment and small tools, enabling the men to carry them over debris and difficult obstacles, to a large extent leaving their hands free to more readily climb over or more about on loose debris. A selection of equipment useful in the early release of trapped casualties is allocated to the men forming the party, so that each carries approximately 30 lbs., additional weight. The fitting and stowage of the various items is standardised and should be adhered to in all demonstrations and practices.

PERSONAL CLOTHING AND EQUIPMENT

3. Each Rescue man will be issued with the following:

<u>Clothing,</u>	<u>No.</u>
Boots	1 pair
Gaiters	1 pair
Helmet, (Fibre glass)	1
Overalls	1 pair
<u>Equipment</u>	
Knife, clasp with marline spike and lanyard	1
Lantern, hand, electric	1
Webbing equipment, including manpack, first aid haversack and water bottle.	1 set

MANPACK EQUIPMENT

4. A standardised manpack has been devised for each member of a Rescue party and is composed of the following items:

	<u>No.</u>
Auger, 1"	1
Bands, webbing (Sets of 2)	1 set
Bar, wrecking, 2'	1
Blanket	1
Bond, wire $\frac{3}{8}$ " x 15'	1
Chisel, cold, 1" blade, 8"-12" stem	1
Cord, sash, 15'	1
Gloves debris	1 pair
Goggles, dust	1 pair
Hammer, club, 2 $\frac{1}{2}$ lb.	1
Hatchet, case opening	1
Mask, dust	1
Pliers, side cutting, insulated	1
Rope, $\frac{1}{2}$ " x 40'	1
Saw, pruning	1
Saw, hack, with 2 spare blades	1
Tool, entrenching	1

FIRST AID EQUIPMENT

5. Each member of the Rescue Service will be equipped with a First Aid Haversack, containing the following items:

	<u>No.</u>
Baking soda tablets, plastic container of 50	1
Bandages, calico 4" x 6 yards.	12
Bandages, constriction	1
Bandages, triangular	3
Butterfly enclosures, packet	1
Casualty labels	25
Crayon wax	1
Dressings, first field	6
Dressings, shell	9
Drinking vessel, 8 oz.	1
Morphia syrettes (1/3 grain)	6
Ointment, tetracaine Ophthalmic, tube	1
Pencil, indelible	1
Salt tablets, plastic container of 50	1
Sheeting, sterilised, 3' x 3' in plastic bag	5

RESCUE VEHICLE EQUIPMENT

6. (a) Each Light Rescue Party will carry the following:

	<u>No.</u>	<u>Carried by Man When Dismounted</u>
Bar, 1" x 5' chisel point	1	No.2 (Deputy)
Hammer, 7 lb.	1	No.3
$\frac{1}{2}$ 14' extension ladder	1	No.4
$\frac{1}{2}$ 14' extension ladder	1	No.5
Rope, 200' x 2"	1	No.6
Shovel, short handles	1	No.7
Snatch block, 3"	1	No.7
Stretcher, Army MK2	1	No.8
Rations, hard	3 days supply.	

(b) Each Heavy Party will carry the following:

	<u>No.</u>
Axe, felling - 4 $\frac{1}{2}$ lb.	1
Bar, picket, 1" x 5', steel	6
Bar, crow, 5'6", chisel point	2
Bar, steel, 10'	1
Blankets, woolien	12
Blocks, wooden spacing	8
Blocks, snatch, 3"	1
Box, nails - mixed - 2 lb. 2"	
2 lb. 3"	1
2 lb. 4"	
Buckets	4
Cutters, bolt $\frac{5}{8}$ "	1
Cutters, pipe $\frac{1}{2}$ " - 2"	1
Cord, sash, 15'	12
Chains, hook and ring, 6'	2
Chisel, plugging	1
Gloves, rubber, insulation	1
Hammer, claw	1
Hammer, sledge, 7 lb.	1
Ladder, 8-14' extending	1
Ladder, 16-30' extending	1
Mattock, cross grubbing	3
Poles, derrick 20'	3
Portable lighting (Service beach light pattern)	2

	<u>No.</u>
Hydraulic Rescue set, comprising:	1
Pump, hand operated, P.76	2
Hose, 6 ft. length with ZH-604 male half of coupler, Z-913	2
Ram 10 ton with ZR-400 female half of coupler and Z-410, R.C.	75 2
Adaptor for 10 ton attachments R-75 - 38A	2
Smooth saddle, R-75 - 45A	2
Hydraulic wedgie with ZR-400 female half of coupler and Z-410 cap, S.A. -4	1
Deep Reach Spread Jaws for attachment to R.C.75 ram, similar to S.A.7 without built in ram	1
Flat Base, Z-14	2
Ram Toe, Z-30	2
Plunger Toe, Z-9	2
Pump, stirrup	2
Rations, hard	3 days' supply for 8 men.
R.B.A. Sets	2
Rope, manilla or sisal, 3" - 200'	1
Rope, manilla or sisal, 2" - 200'	1
Rope, manilla or sisal, 1½" x 40'	12
Rope, wire, ½" x 50'	2
Saw, hand	1
Saw, Bushman's, 36"	1
Saw, Cross-cut, 6'	1
Shackle, 'D' type	1
Shovels, medium,	2
Shovel, short,	2
Spanner, crescent 15"	1
Screwdrivers, 9"	2
Stretchers, folding (Army MK2)	6
Tarpaulin, 10' x 10' approx.	1
Tape, measuring 6'	1
Tirfor, hauling and lifting, type T.13	1
Snatch block for Tirfor	1
Wrench, Stillson, 30"	1
Wheelbarrow	1
Wedges, wooden	8
<u>Optional Equipment.</u>	
Chain saw	1
Oxy-Acetylene cutting torch, complete	1
Acetylene cylinder	1
Oxygen cylinders	2
Portable pump, 4,000 g.p.h.	1
Portable lighting unit (electric)	1

CONCLUSION.

It has been the purpose of this circular, to outline the man-pack and personal equipment, used by Rescue personnel. This equipment will enable Rescue Parties to work forward, from their vehicles into heavily damaged areas, carrying out the major portion of the rescue tasks, facing them.

S.A. POLICE DEPARTMENT

EMERGENCY FIRE SERVICES

ROPES, WIRE ROPES AND KNOTS

NOTES FOR INSTRUCTOR:

1. The Instructor will require one each of the fibre ropes used in rescue.

OBJECT.

2. The object of this paper is to outline the various fibre ropes used in rescue, their general care and maintenance, and to teach knots and lashings.

INTRODUCTION.

3. Rescue Parties are supplied with various sizes of fibre ropes and also with steel wire ropes. They all require continual attention and care if their usefulness is to be maintained.

4. Both fibre and wire ropes are made up of three or more strands twisted together. The size of manilla and other fibre ropes is denoted by the circumference of the rope in inches. Thus a 3 inch rope has a circumference of about 3 inches, and is about 1 inch thick. The size of a wire rope is indicated by its diameter in inches; i.e., a 1/4 inch wire rope means a wire rope 1/4 inch thick.

FIBRE ROPES.

5. The ropes supplied to the Rescue Section will be referred to as fibre ropes.

6. Just as the strength of a chain depends on the strength of its weakest link, so the strength of a rope is that of any frayed or decayed portion of it.

7. For safety in working, members of Rescue Parties must know the strength of the ropes they use. As a rough rule, the safe working strength of a new, dry fibre rope in hundred-weights can be taken as its circumference (in inches) squared. Thus, - the safety load of a new 3 (three) inch fibre rope is about 3 x 3 - 9 cwt.

8. Untarred ropes are stronger than tarred ropes. Three-stranded ropes are stronger than four-stranded ropes.

9. The strength of a rope is greatly reduced if it is -

- (a) Stored wet;
- (b) Treated with oil;
- (c) Knotted - because the stress on the fibres is not uniform, the outer fibres are subject to the greater strain and may fail;
- (d) Passed over a sharp edge, - this tends to cut and chafe the rope, causing permanent damage;
- (e) if the load comes on with a jerk.

UPKEEP AND CARE OF ROPES.

10. Ropes are a vital part of rescue equipment. They must be kept in good condition so that they will be sound and thoroughly efficient when brought into use for rescue work, e.g. for lifting weights and releasing trapped persons.

11. New ropes are supplied in coils. A new coiled rope is uncoiled by laying the coil on one side so that the end of rope in the centre is at the bottom and the bands loosened.

✓
Ropes, Knots and Lashings:

-2-

UPKEEP AND CARE OF ROPES - continued :

12. The method of bringing the bottom end out first is, strictly speaking, dependent upon how the coil was reeled, i.e., from the left or right-hand side of the reel. To avoid disturbing the balance of lay, either into or out of the rope, the ideal method is to rotate the coil when uncoiling.

CARE OF FIBRE ROPES.

13. To ensure the efficiency of fibre ropes, ALWAYS :-

- (a) Stretch a new rope throughout its length before using it. To do this attach one end to a swivel hook (to allow of twisting), and haul on the rope.
- (b) Avoid cutting a rope unless it is essential to do so. If it is necessary, ensure that the cut end is whipped as soon as possible to prevent fraying. As a temporary measure to prevent fraying, tie a figure of eight knot near the end of the rope. Adhesive tape is also useful as a quick temporary whipping.
- (c) Avoid permanent knots in a rope, as these considerably reduce its strength.
- (d) Do not attempt to force a thick rope through a tackle made for a smaller rope. This produces a strain on the rope and lessens its strength.
- (e) Avoid passing a rope over a sharp edge. If it is necessary to do this protect the edge with a sandbag or a piece of rounded timber.
- (f) Avoid sudden jerks or violent stress on the rope as this weakens both the rope and any tackle used with it.
- (g) As far as possible, keep a rope dry. If it gets wet, do not attempt to dry it in front of a fire. Spread it on a ladder laid horizontally off the ground to enable the air to circulate freely round the rope.
- (h) Store fibre ropes under cover off the floor, preferably on racks in a place free from extremes of temperature and out of contact with materials containing any acid or strong alkali, e.g., creosote. Also free from rats if possible.
- (i) Examine ropes regularly for external damage and rotting of fibres.
- (j) If coiled rope has to be left in a place where it may be exposed to the weather, cover it with tarpaulin or some other form of protection.
- (k) Whenever a rope has been used, ensure that it is clean and dry before it is coiled and put away.

TERMS USED IN CONNECTION WITH ROPES

1. Anchored - fastened to some immovable object, such as a large tree, post or a well driven picket.
2. Bight - an open loop in a rope.
3. Frapping - the binding together of a lashing between two poles.
4. Haul - the act of pulling on a rope.
5. Hitch - a closed loop on a rope; a simple fastening of a rope around some object by winding and crossing one turn over another turn so that one bites on the other without actually knotting the rope.

Ropes, Knots and Lashings.

-3-

Terms used in connection with ropes - continued :

6. Mousing - tying a piece of cord across the jaws of a hook to prevent a rope or sling from jumping out when the weight is temporarily supported.
7. Parcelled - when part of a rope is wrapped to prevent chafing.
8. Paying out or Easing - to ease off or slacken a rope.
9. Reeve - the threading of a rope through pulley blocks or snatch blocks.
10. Round Turn - one complete turn of a rope round a spar or another rope.
11. Running End - the free end of a rope.
12. Standing Part - the part of a rope which is taking the load.
13. Whipping - binding the end of a rope with twine to prevent untwisting or fraying. Whipping is also used to bind the loose end of a rope to the standing part.

STEEL WIRE ROPES.

1. Steel wire ropes are about nine times as strong as corded ropes of the same thickness. The wire bonds ("scaffold lashings") used by the rescue section are 1/4 inch diameter (3/4 inch circumference). If in good condition they will take a load of approximately - 3/4 x 3/4 x 9 = 5 cwt.
2. The recommended minimum diameter about which a steel wire rope can be bent without causing harm to the rope is six times the circumference of the steel wire rope, e.g. 5/8 inch diameter steel wire rope equals 2 inch circumference, which, times six, equals 12 inches minimum diameter. It is not advisable to use steel wire rope with fibre rope pulley blocks.
3. Steel wire ropes should be cleaned with a rag and well oiled before storing away. When coiled, the coils must not be so small as to damage the strands.

Lubrication of steel wire ropes

<u>ROPE</u>			<u>LUBRICANT</u>
Galvanised Small Cords	Dry
Galvanised Flexibles	Petroleum Jelly
Galvanised Punt Ropes	Graphite
Haulage Ropes	Graphite or Crater Compound for wet conditions
Winding Ropes	Graphite or Hodson's Compound for wet conditions
Earth Moving Equipment and Shovel Ropes	Graphite
Logging Ropes	Graphite
Scraper Ropes	Graphite

-----oOo-----

(Ref. C.D. Rescue Manual, R.S.5.)

SAFE WORKING LOAD ROPES

DIA.	CIRCUMFERENCE		FIBRE ROPES	STEEL ROPES
	EXACT	APPROX.	SAFETY LOAD	SAFETY LOAD
1/8"	0.3927"	3/8"	0.141 cwt	1.269 cwt
5/32"	0.4909"	1/2"	0.250 "	2.250 "
3/16"	0.5890"	5/8"	0.391 "	3.519 "
1/4"	0.7854"	3/4"	0.562 "	5.058 "
9/32"	0.8836"	7/8"	0.765 "	6.885 "
5/16"	0.9817"	1"	1.000 "	9.000 "
3/8"	1.1781"	1-1/8"	1.205 "	10.845 "
7/16"	1.3745"	1-3/8"	1.890 "	17.010 "
1/2"	1.5708"	1-5/8"	2.640 "	23.760 "
9/16"	1.7672"	1-3/4"	3.062 "	27.558 "
5/8"	1.9635"	2"	4.000 "	36.000 "
11/16"	2.1598"	2-1/8"	4.515 "	40.635 "
3/4"	2.3562"	2-3/8"	5.640 "	50.760 "
13/16"	2.5525"	2-1/2"	6.250 "	56.250 "
7/8"	2.7489"	2-3/4"	7.562 "	68.058 "
15/16"	2.9452"	3"	9.000 "	81.000 "
1"	3.1416"	3-1/8"	9.765 "	87.885 "
1-1/16"	3.3379"	3-3/8"	11.390 "	102.610 "
1-1/8"	3.5343"	3-1/2"	12.250 "	111.250 "
1-1/4"	3.9270"	3-7/8"	15.015 "	135.135 "
1-3/8"	4.3197"	4-3/8"	19.140 "	172.260 "
1-1/2"	4.7124"	4-3/4"	22.562 "	203.058 "

1 Gross or Lons Ton = 2240 lbs = 20 cwt;

1 cwt = 4 quarters = 112 lbs;

1 quarter = 28 lbs = 2 stone; 1 stone = 14 lbs.

NOTE: Calculations based on new ropes only.

S.A. POLICE DEPARTMENT
EMERGENCY FIRE SERVICES

KNOTS AND LASHINGS

STANDARD KNOTS.

The following is a list of knots, bends and hitches with which every Fireman and Rescue Section should be acquainted and the more important of which should be able to be made blindfold. The knots given below should suffice for all normal Fire Services and Rescue Section purposes.

Standard Terms:- There are a number of standard terms for use in describing parts of a knot, etc., and the following should be learnt and understood by every member.

BEND. - To fasten a line to another line or to an object.

BIGHT - The looped or loose part of a line between the two ends.

HITCH - A simple fastening of a line to some object by passing the line round the object and crossing one part over the other.

RUNNING PART - The moving part of a line which is loose and used to hoist or lower.

RUNNING END - The free end of a line.

SEIZING - The binding together of two or more ropes.

STANDING PART - The part of a line which is fixed.

WHIPPING - The binding of the end of a line with twine to prevent it unlaying.

ANCHORED - Fastened to some immovable object, such as a large tree, post, or well driven picket.

FRAPPING - The binding together of a lashing between two poles.

MOUSING - Tying a piece of cord across the jaws of a hook to prevent a rope or sling from jumping out when the weight is temporarily supported.

PARCELLED - When part of a rope is wrapped to prevent chafing.

PAYING OUT OR EASING - to ease off or slacken a rope.

REEVE - The threading of a rope through pulley blocks or snatch blocks.

LASHINGS - Lashings are used mainly to secure two or more poles firmly together. The form of each type of lashing can best be understood by a careful study of the circular "Lashings". The lashings may be made by using the 40ft x 1½" lashings carried in the equipment.

Square Lashing - This is used to lash together two poles that touch and cross at right angles.

Diagonal Lashing - This is used to lash together two touching poles at an angle, especially when their mode of use may cause them to spring apart.

Round Lashing - This is used to lash two poles which lie parallel to each other.

Figure-of-Eight Lashing - This used to lash three parallel poles together, as may be necessary to form a triped or gin (Gyn.)

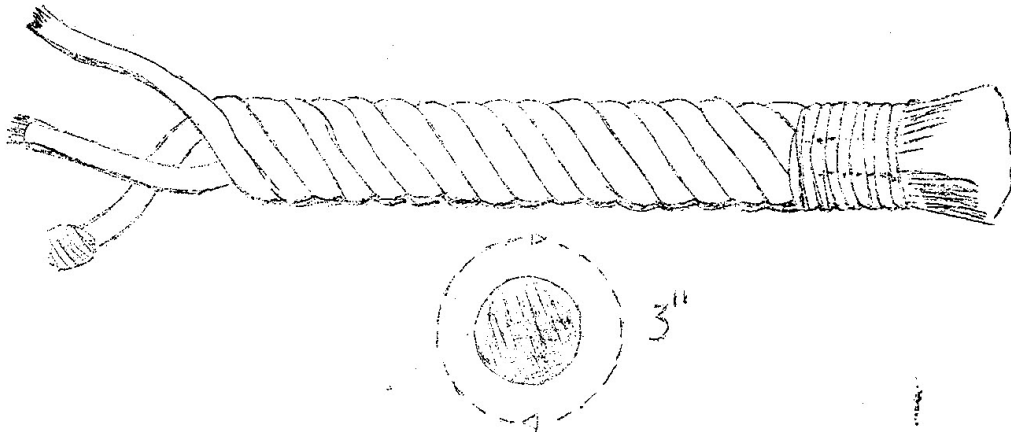
KNOTS

Both Fibre and Wire Ropes are made up of three or more strands twisted together. The size of Manilla and other fibre ropes is denoted by the circumference of the rope in inches. Thus, a 3 inch rope has a circumference of about 3 inches, and is about 1 inch thick. The size of a wire rope is denoted by its diameter in inches; i.e., a $\frac{1}{4}$ " wire rope means a wire rope $\frac{1}{4}$ " thick.

Standing Part.

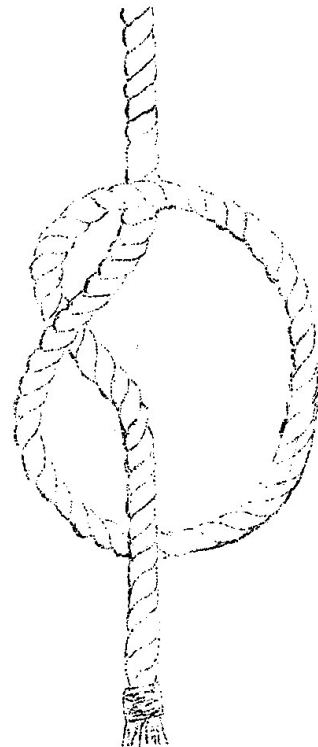
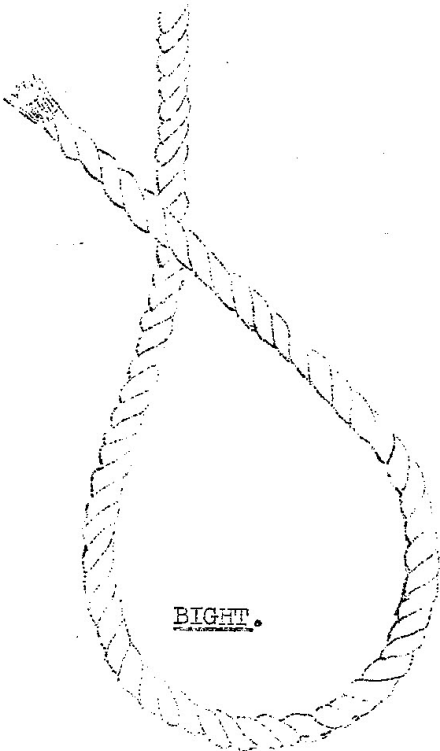

Running End - The free end of a line.

Standing Part - The part of a line which is fixed.

Bight - The looped or loose part of a line between the two ends.

OVERHAND KNOT:- Sometimes known as a Thumb Knot. Used as a simple stopper, and tied at each end in lengths of burst hose when laid out. This simple knot can be tied in the end of a rope to stop the rope passing through a pulley block or temporarily to prevent fraying of an end.

FIGURE-OF-EIGHT KNOT.



Used as a stop, e.g. to prevent a line running through a sheave, is put in the end of a rope to prevent it from unreeving.

REEF KNOT.

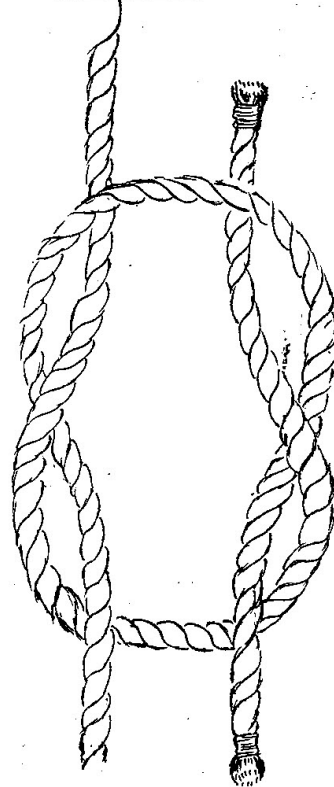

For joining two ropes of equal thickness.

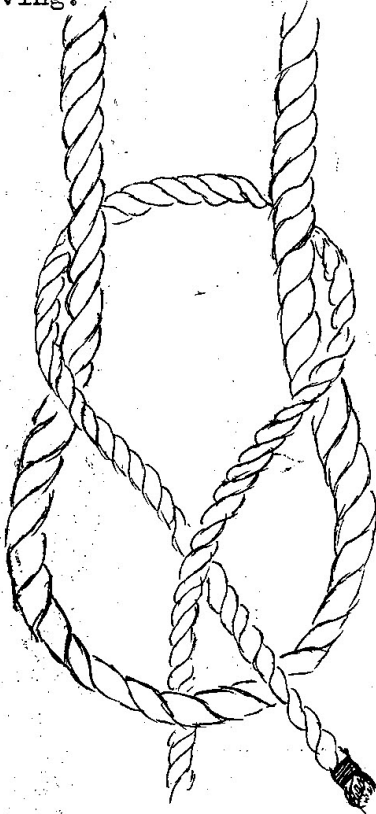

SINGLE SHEET BEND.

Used to join two lines of unequal thickness.

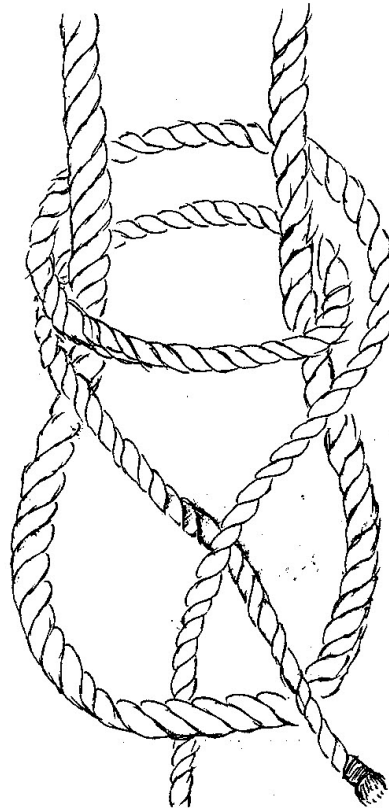

DOUBLE SHEET BEND. A slightly more secure version of the single sheet bend. Used when big difference in size of ropes.

BOWLINE

Bowline:- This forms a non-slip loop at the end of a rope and is a most useful anchoring knot. It may also be used for lowering or raising purposes and for attaching a rope to a person as a safety line.

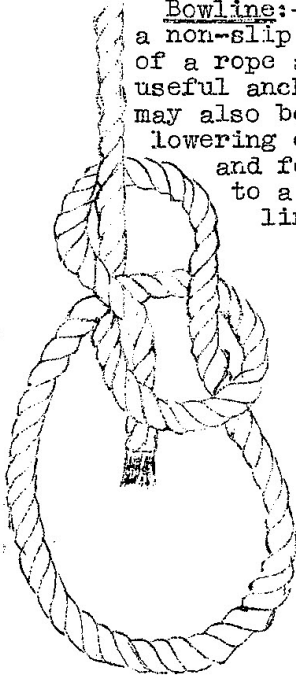

MOUSING

Mousing:- Tying a piece of cord across the jaws of a hook to prevent a rope or sling from jumping out when the weight is temporarily supported.

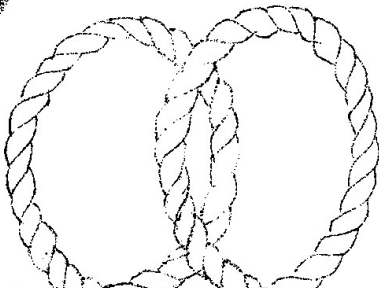
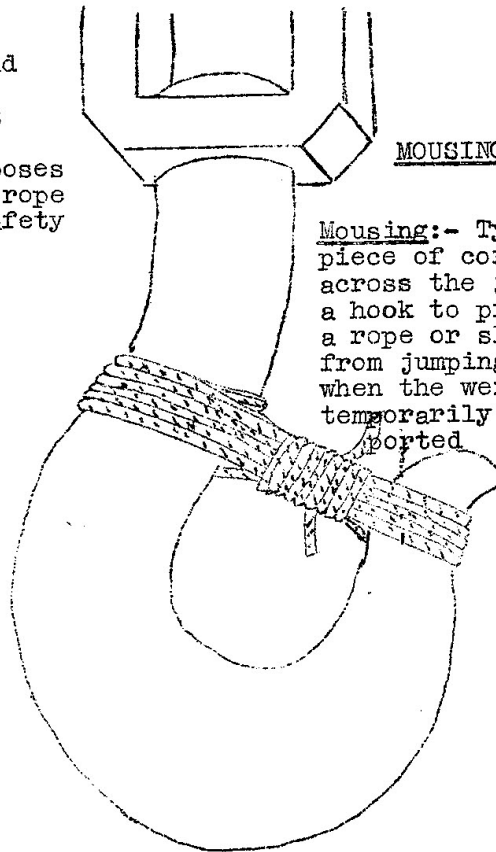

Half Hitch:- used in conjunction with other knots for securing suction, hoisting up a branch, etc.

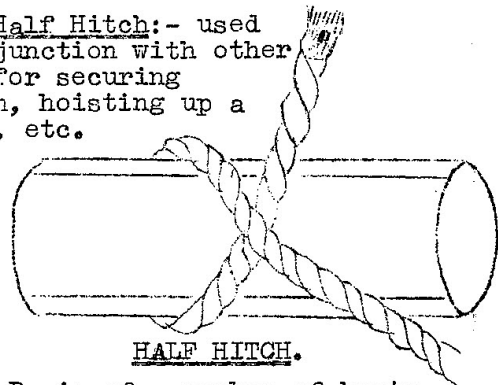

GLOVE HITCH CENTRE OF ROPE.

is forms the basis of many securing knots and can be used in the end of a rope or in the centre. Used to secure a line to any round object.

GLOVE HITCH END OF ROPE.

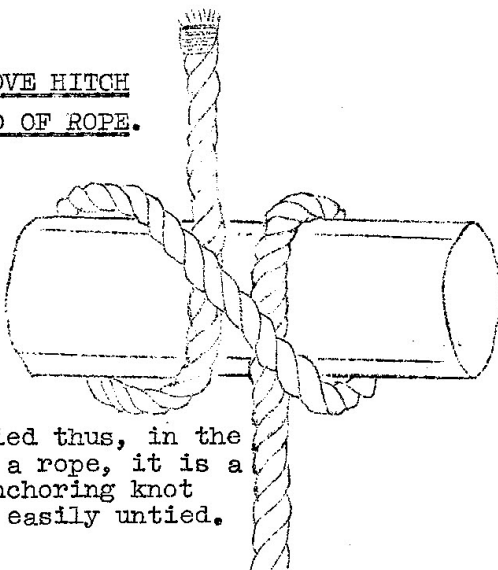

When tied thus, in the end of a rope, it is a good anchoring knot and is easily untied.

HALF HITCH.

Basis of a number of knots
Civil Defence use - Stretcher Lashings
Making lines fast - often used as two half hitches for attaching ropes to objects such as poles or hooks. Used for securing suction hoses, hoisting

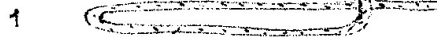

SHEEP SHANK - Used to shorten a length of a line.

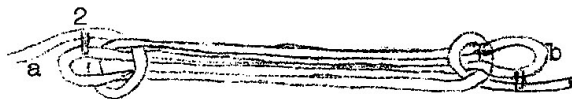

The ends of the sheep-shank should be seized. Bights a and b should be seized to the standing parts.

ROUND TURN AND TWO HALF HITCHES.

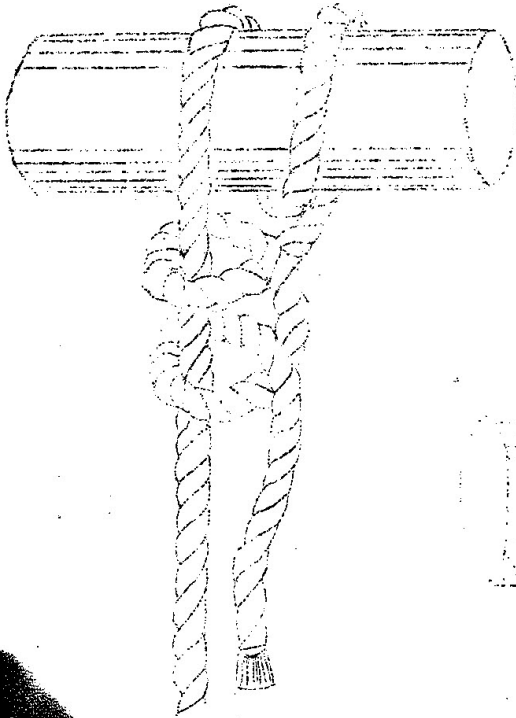

secure a line to any round object or ring.

TIMBER HITCH.

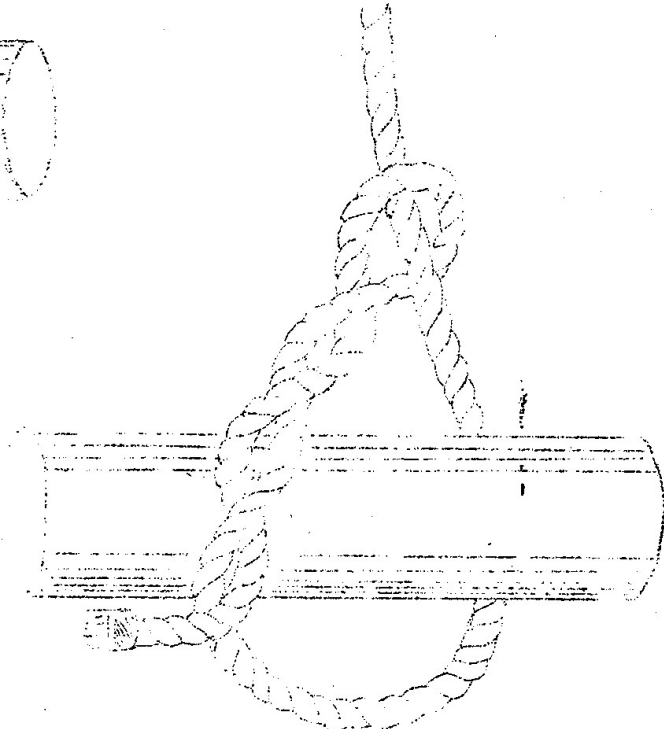

A simply made knot used to hoist any irregularly shaped object such as a baulk of timber; plank or pole. When a continuous strain is exerted it is advisable to supplement the Timber Hitch with a half hitch.



ROUND TURN.

One complete turn of a rope round a spar or another rope.



DRAW HITCH - This Hitch will stand considerable strain on the standing part and yet can be easily released by jerking the free end. It enables the rope to be recovered from places where the knot cannot be reached and untied by hand. It is not considered reliable when used on a square holding.



RUNNING BOWLINE.

Forms a running noose. Consists of a Bowline made on the standing part of the rope.



HALF HITCH.

The basis of a number of knots.



OVERHAND KNOT

Used as a simple stopper, and tied at each end in lengths of burst hose when laid out.



ROLLING HITCH.

Used to secure a line to any round object so that the knot will not slip along the object when a sideways pull is applied.

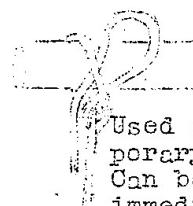

SLIPPERY HITCH.

Used as a temporary fastening. Can be released immediately by pulling on the short end.

CHAIR KNOT.

The Chair knot is a good general purpose knot and one which is very important for emergency rescue work. One of its main purposes is to form an efficient and quickly made sling in which a person may be readily raised or lowered. The sling formed by this knot gives support to the chest and legs of the person being rescued. One loop will be slightly larger than the other to keep the person being raised or lowered in a "chaired" position.

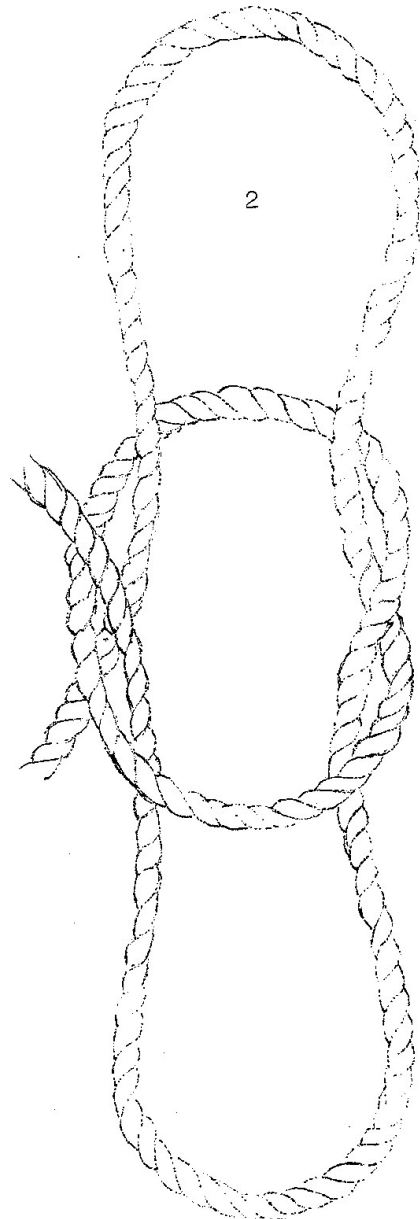
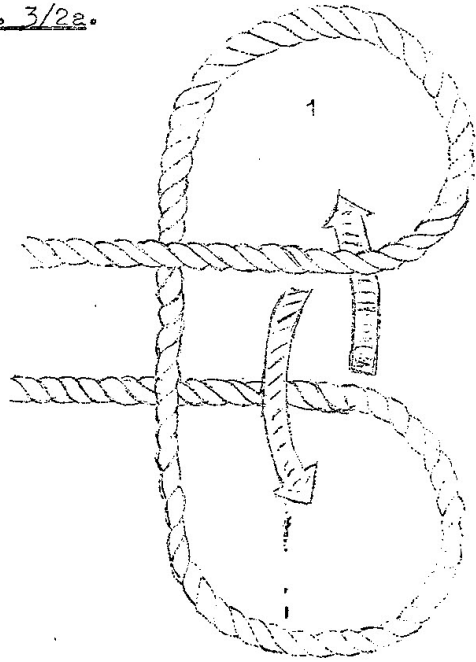
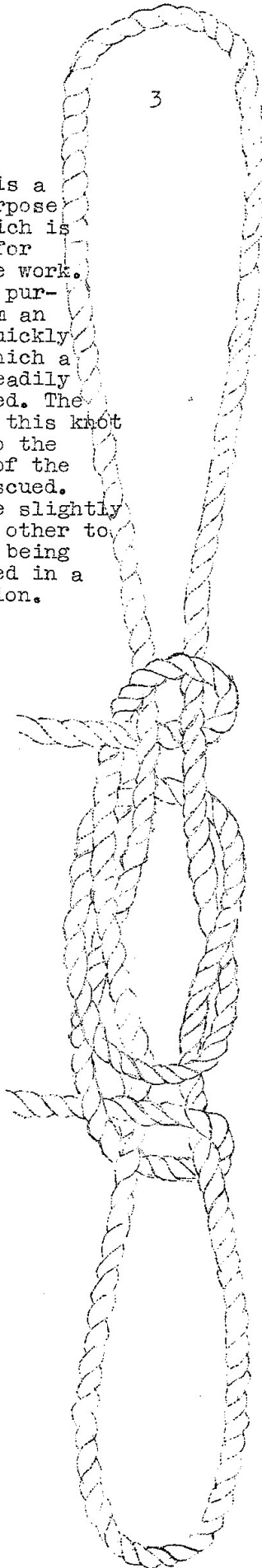

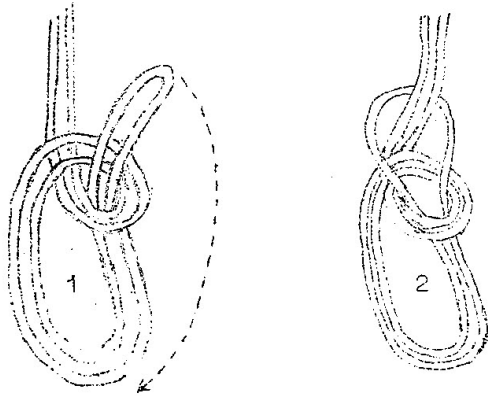

BOWLINE ON EIGHT.

Used as a sling to lower insensible person; one bight being placed under the person's arms and the other under the thighs.

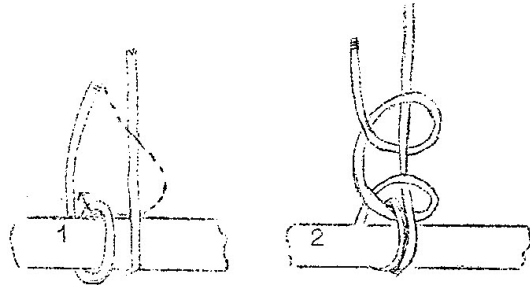

FISHERMEN'S BEND.

A variant of the round turn and two half hitches. Makes a fastening free to move since it does not pull tight under strain. The end must be seized to the standing part.

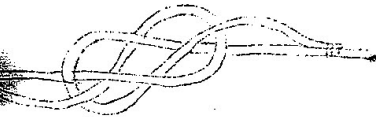

CARRICK BEND.

Used to join two lines together, especially when the knot may be required to pass round an object, since it lies evenly and does not form an obstruction when paying out.



WATERMAN'S HITCH.

Used to secure a skiff to the towing bitt of a fireboat. It can be made and cast off when under strain on the standing part.

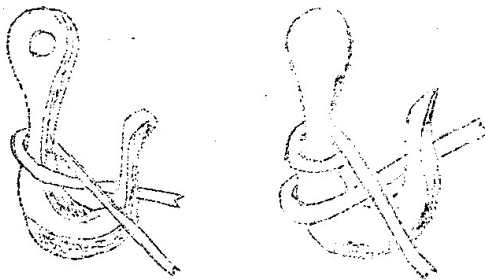

(a) BLACKWALL HITCH. (b) DOUBLE BLACKWALL HITCH.

A Blackwall Hitch consists of a half hitch. This is made on the shank of a hook in such a way that the free end is locked by the strain on the standing part. Used for a short haul.

A Double Blackwall Hitch holds better than a blackwall hitch and is used for the same purpose.



REEF KNOT

A Reef Knot is the simplest of all knots, and is always used when a common tie is required. Its formation is easily traced in Figs. 1 and 2. Used to join two lines of equal thickness.

WHIPPING

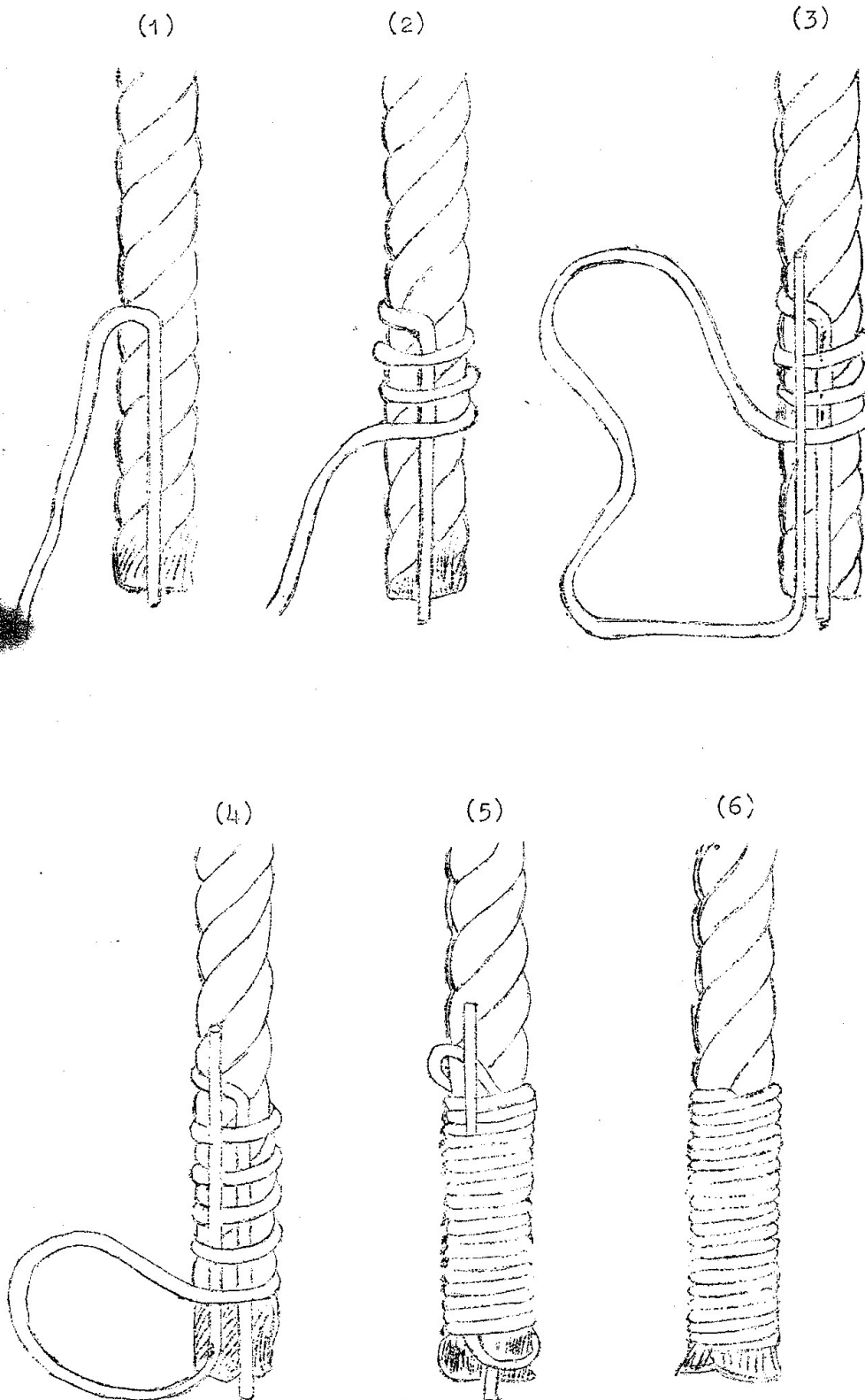

Whipping:- Binding the end of a rope with twine to prevent un-twisting or fraying. Whipping is also used to bind loose end of a rope to the standing part. The above method is the more common type of whipping.

FIGURE-OF-EIGHT LASHING.

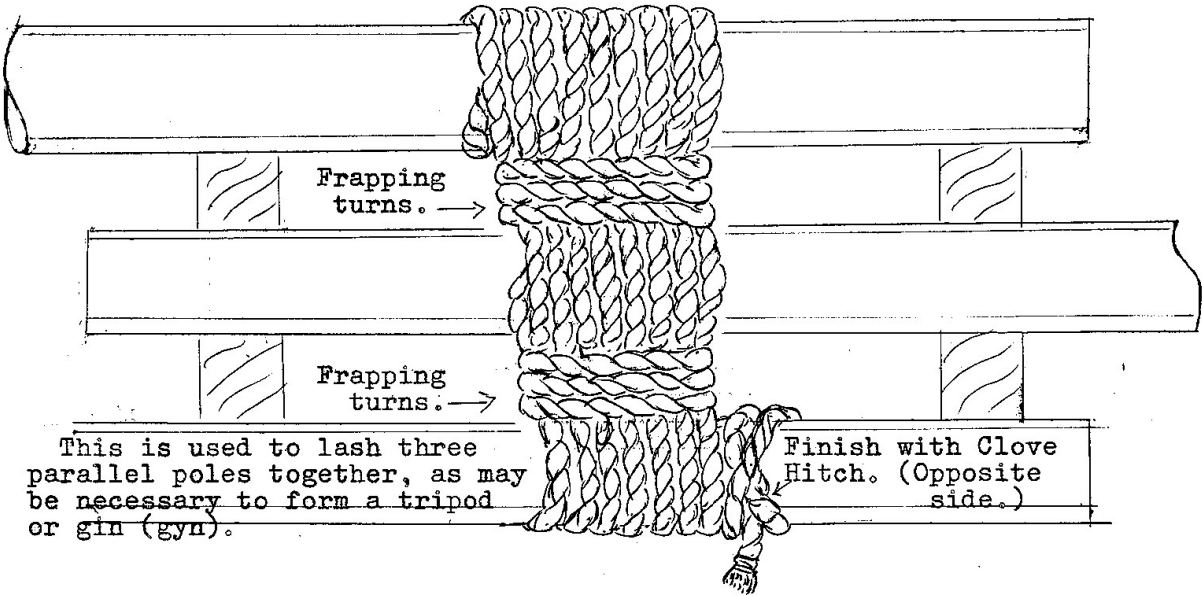
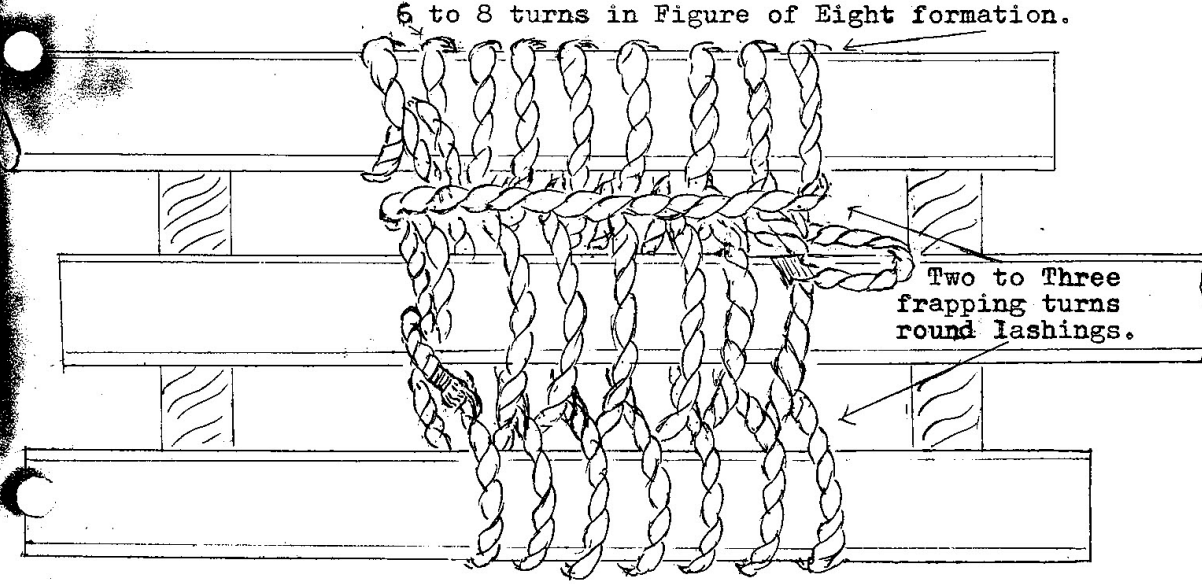
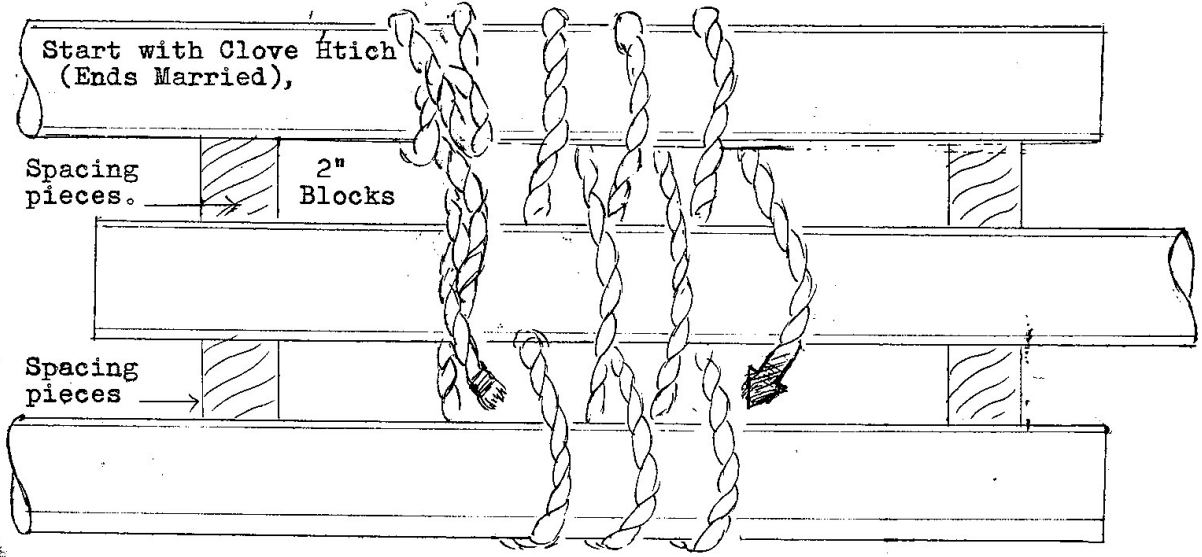

This is used to lash three parallel poles together, as may be necessary to form a tripod or gin (gyn).

ROUND LASHING.

2" Spacing pieces

2" Spacing pieces

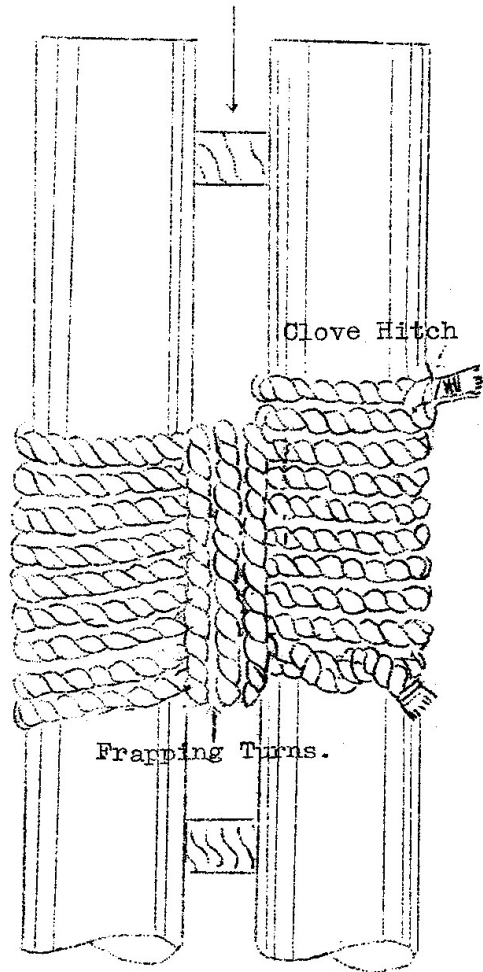
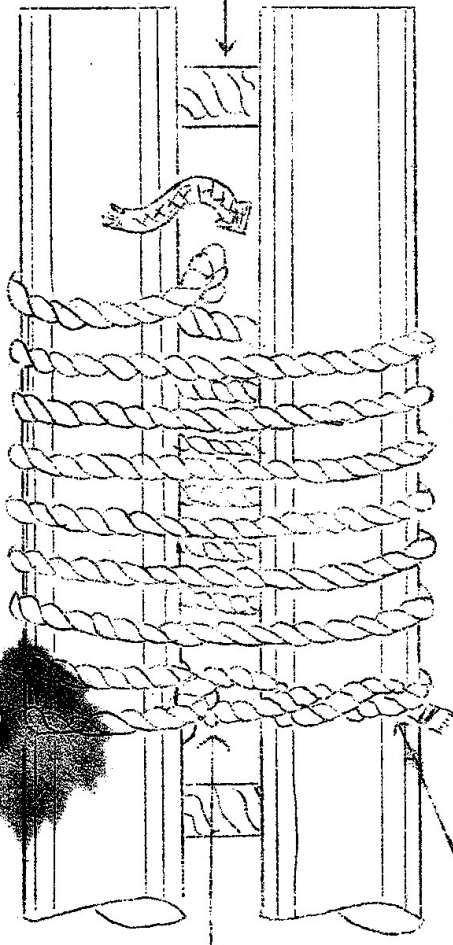

Start with Clove Hitch, (Married ends.)
 Make 6 or 8 close turns
 round both poles.

ROUND LASHING.

This is used to lash together two poles which lie parallel to each other.

METHOD. Insert spacing pieces.

Start lashing with a clove hitch round one of the poles (ends "married") and continue with 6 - 8 close turns round both poles, travelling upwards, make two or three frapping turns round the lashing, between the poles, finishing off with a clove hitch above the lashing and on the opposite pole to the beginning of the lashing.

FIGURE-OF-EIGHT LASHING.

This is used to lash three parallel poles together, as may be necessary for instance, to form a tripod or gin (gyn).

Spacing pieces about two inches wide should be inserted. Start with a clove hitch round one of the poles, with the ends "married". Working upwards all the time from the first clove hitch, continue lashing in figure-of-eight fashion with 6-8 turns. Make two or three frapping turns round the lashing, repeat on other side. Finish with a Clove Hitch on the opposite pole to the beginning of the lashing. (See illustration, separate page

DIAGONAL LASHING

EMR/DP 3/2a-1964

This is used to lash together two touching poles at an angle, especially when their mode of use may cause them to spring apart.

STAGE 1.

Start with a timber Hitch (a) round both poles horizontally, then take four vertical turns (b) and draw all taut.

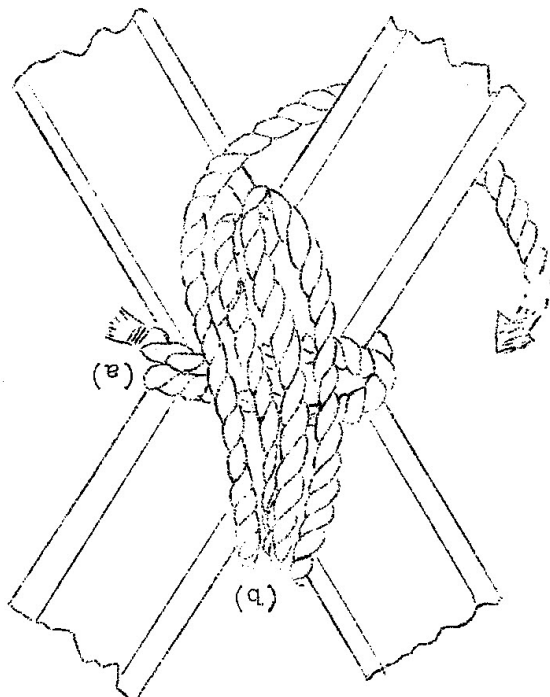

STAGE 2.

Take four horizontal turns (c) and draw taut.

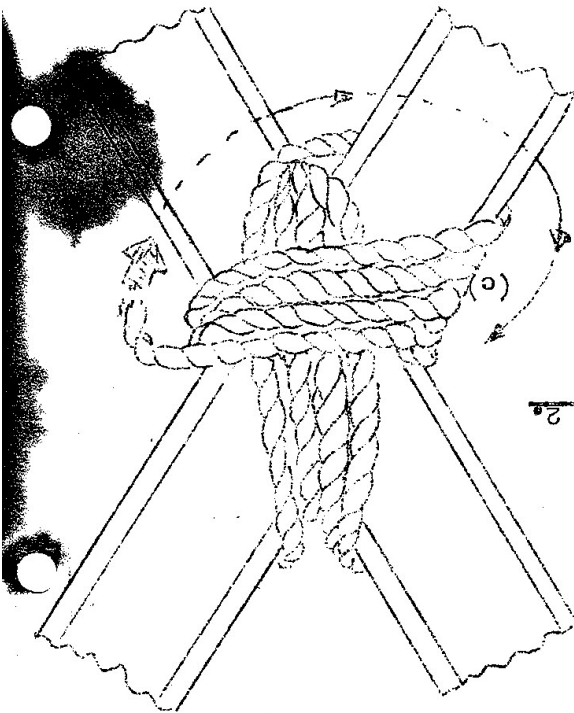

STAGE 3.

Finally, put four trapping turns (d) over the lashing, and finish with a clove hitch (e).

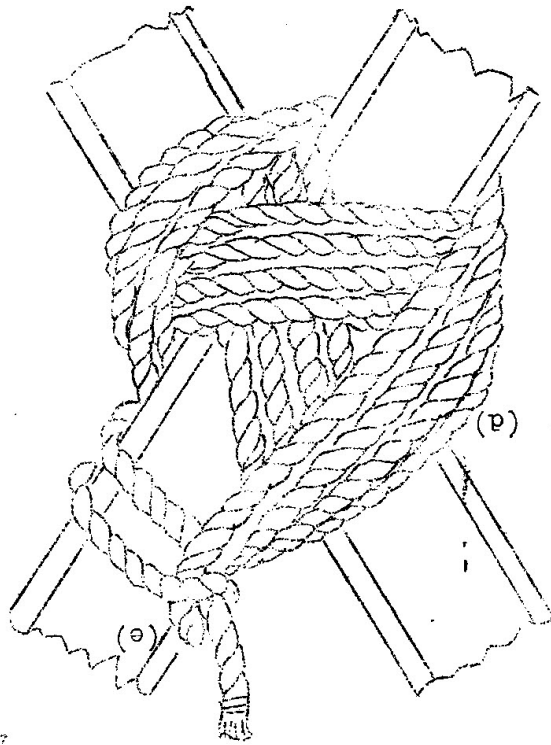

SQUARE LASHING.

Standard →

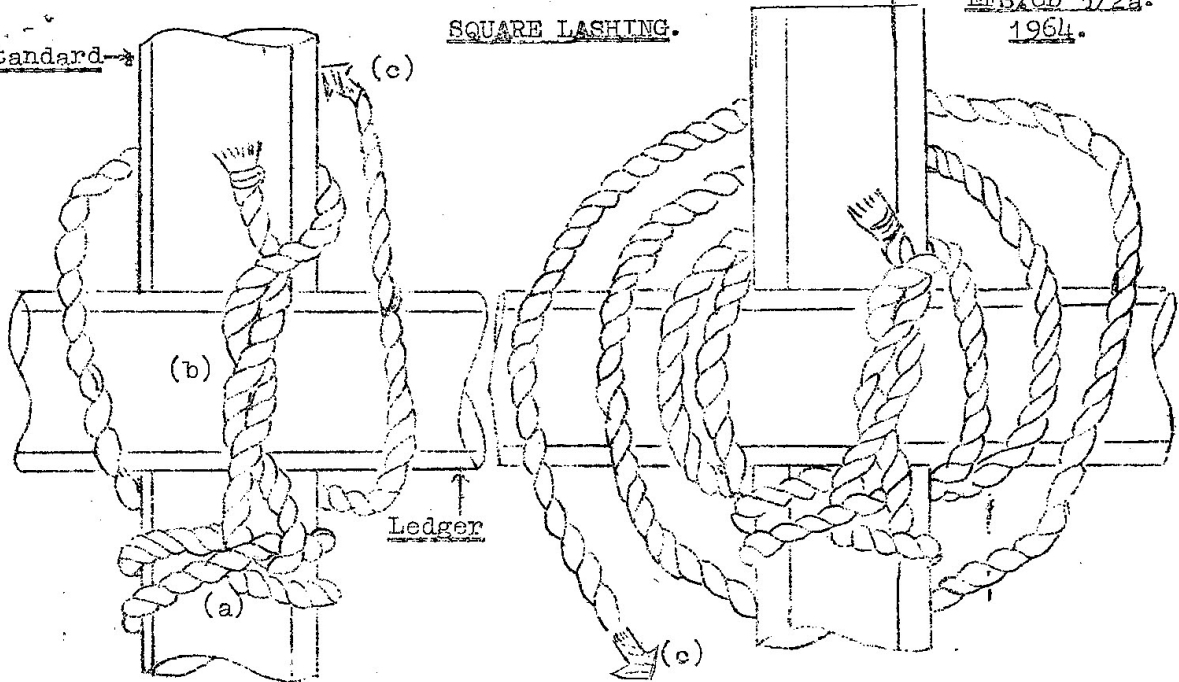

SQUARE LASHING:- This is used to lash together two poles that touch and cross at right angles.

1. Start with a clove hitch (a) on the standard, below the ledger, the ends as at (b). Take the ends up and around both spar and ledger as depicted (c).

Stage 2. Repeat this circuit three or four times, drawing the rope as taut as possible.

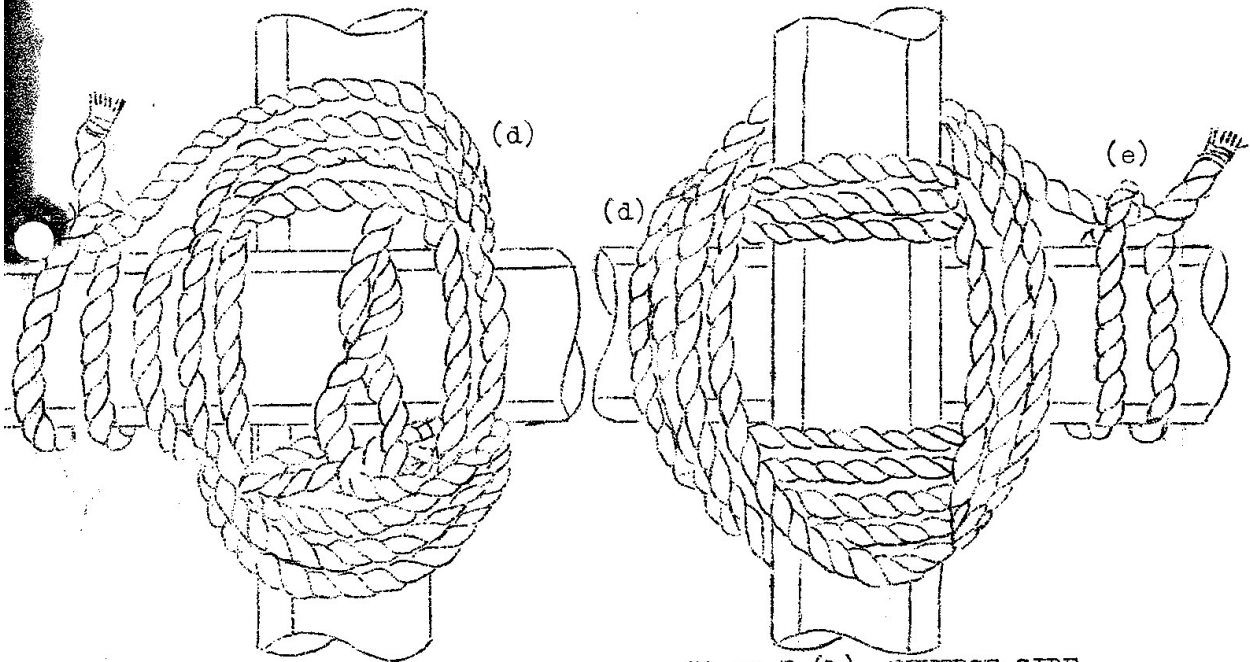

Stage 3 (a). Take three or four frapping turns (d) around the whole lashing between the spars, draw taut and finish with a clove hitch (e) on the ledger.

Stage 3 (b). REVERSE SIDE. The square lashing complete as viewed from the back.

S.A. POLICE DEPARTMENT
EMERGENCY FIRE SERVICES
Police Barracks
THEBARTON

EFS/CD No. 4/9
1964.

1, LADDER HINGE RESCUE DRILL

For lowering a stretcher from a height with the use of a ladder. Although this operation can be carried out with three men, it is recommended that at least four men should be used.

- (a) The ladder is placed vertically against the face of the wall or building from which it is intended to lower the casualty. At a height of about ten inches above the window opening the foot of the stretcher is secured to the ladder by means of a 15 ft. sash cord lashing.
- (b) The casualty should be secured to the stretcher in the normal way, (See E.F.S. / C.D. No. 4/3) and the head of same supported by any available furniture, thus leaving the two men free to carry out the lashing operation at the foot. The lashing is begun by passing the sash cord through the left hand stretcher 'D' and secured with a bowline. A half hitch is then taken around the left hand ladder string and on top of a rung sufficiently high up to allow about 10 inches clearance between the bottom of the stretcher and the window opening. Eight or ten round turns are then taken across the rung and a similar half hitch on the right hand ladder string. A round turn is then passed through the right hand 'D' and at this stage the stretcher is adjusted for equilibrium before this round turn is made off with two half hitches. Enough slack should be left in the lashing to permit hinging throughout the operation. Finally two 40 ft. lashings are attached to the "D's" at the head of the stretcher by means of a bowline.
- (c) The casualty is then ready to be lowered to the ground, the operation being performed as follows:-

The two men on the ground stand at the bottom of the ladder, facing it, with their hands gripping the sides of the ladder. As the lowering commences, they walk slowly backwards in the normal manner of lowering a ladder, allowing it to fall at an angle, the bottom being held against the base of the wall, which forms the fulcrum points.

The two men at the rear end of the stretcher pass the casualty out, feet first, through the window but before passing the end of the stretcher beyond the wall, take the weight onto the two lowering ropes and allow the stretcher to ride out clear of the window opening.

Lowering is continued evenly, keeping the stretcher horizontal, until the ladder lies on the ground with the stretcher on top of it.

- (d) If an additional man is available he should stand with arms extended and help support the ladder as it comes over the vertical. Walking backwards with hands moving from rung to rung, he can greatly assist the two men lowering from the upper floor. The two men normally on the ground remain at the foot of the ladder with their hands on the ladder strings and prevent any side sway which may occur during the lowering operation. It is pointed out that if this method is used for floors above the first floor, guide lines should be attached to the top of the ladder and manned by an additional two men on the ground. This being an additional two men on the ground. This being an additional precaution against side sway.

LADDER HINGE DRILL - (8 MEN)

RESCUE PART 'FALL IN'

Single line - at ease

"Atten-shun" - "Right dress" - "Eyes Front" - "Number" -
"Stand-at-ease"

RESCUE PARTY COMMAND:

- No. 1 Party Leader
- No. 2 Deputy Party Leader
- No. 3 Driver - Storeman
- Nos. 4 to 8 Rescue Party Men

DRILL DUTIES FOR LADDER HINGE:

- Nos. 6, 7 & 8 (Ladder crew), - provide and position ladder, (Nos. 6, 7 & 8 take positions of ladder crew 1, 2 and 3 respectively).
- No.1 Ascends, makes recce, descends, instructs Party.
- No.2 Ascends with two blankets, (slung over shoulder), sash cord, - prepares and blankets stretcher.
- No.4 Ascends with 3 x 40ft. lashings, (hung over arms or shoulder), hauls up stretcher and any other gear.
- No.5 Attaches stretcher and any other gear to line for No. 4 (clove hitch and half-hitch), stands by to assist.
- No.3 Hands out gear from Rescue Vehicle - remains within hailing distance of vehicle.
- Nos.2 & 4 Load casualty onto stretcher, lash and attach lowering lines.
- Nos.2 & 4 Lash stretcher to the ladder, (see 1 (b) page 1).
- Nos.6, 7 & 8 Lower ladder, Nos. 6 & 8 supporting strings. No. 7 under-runs or foots ladder as necessary.
- Nos.2 & 4 Pay-out lowering lines.
- Nos.5 & 7 Release stretcher, remove sash cord - Transport casualty - hand over to 1st Aid Party and return to Rescue Party.
- Nos.6 & 8 Re-position ladder.
- Nos.2 & 4 Descend.
- Nos.6, 7 & 8 Make-up ladder.
- No.3 Makes up equipment, ropes, etc., - check area for gear, - check gear on vehicle.

For drill purposes, Rescue Party Men, whilst not engaged in actual work, will stand at ease, facing tower, awaiting orders.

S.A. POLICE DEPARTMENT
EMERGENCY FIRE SERVICES
Police Barracks
THEBARTON

LADDER SLIDE RESCUE DRILL

1. Where the height of a window still permits, a stretcher may be lowered by attaching restraining ropes to the head and tilting it so it slides down an inclined ladder. Pick handles are passed through the stretcher "D's" to facilitate its sliding down the ladder.
2. This method cannot, however, be used when the nature of the casualty's injuries necessitates a stretcher being kept in a horizontal position.
 - (a) The ladder is positioned, extended and placed in position against the building; head of the ladder should be lashed.
 - (b) Two men mount the ladder, taking with them the necessary equipment for dealing with the casualty, who must be blanketed and lashed to the stretcher. In addition, two pick handles for insertion into the "D's" of the stretcher, and at least two 40 ft. lashings, or more if required, according to height.
 - (c) With the casualty securely lashed to the stretcher, the pick handle is passed through the top "D's" of the stretcher, held in position by the restraining lines which, after they have been fastened over the handles and through the "D's" by bowlines, are given a round turn on the pick handles, followed by a half hitch on the handles. Where the opening is narrow, the pick handle may have to be inserted into the "D's" as the stretcher is passed through it.
 - (d) The third man mounts the ladder when everything is in readiness to slide and prepares to receive the foot of the stretcher as it is passed out to him. The other two take up position at ground level, one 'footing' the ladder and the other acting as a human support or brace under the back of the ladder to take part of the strain.
 - (e) The man on the ladder takes a firm grasp of the handles at the foot of the stretcher and eases it gently over any obstructions as he slowly descends, while the men at the top, controlling the restraining lines, can exert added 'lift' to ease the head over such obstructions.
 - (f) When sufficiently near to ground level for the two men to assist, they move round to the sides of the ladder, ready to take charge of the stretcher as it descends, gently lower it to the ground, remove the restraining lines and pick handles and carry the stretcher away.
3. A pick handle at each end of the stretcher is necessary. The lower one to prevent the lower traverse bar from fouling any part of the ladder thus tending to close the stretcher. It also helps to keep the stretcher and lashing off the ladder. The top one enables the stretcher to slide smoothly on the beams of the ladders, but it must be secured with equal projection at each side.
4. These pick handles raise the stretcher off the ladder sufficiently to prevent the sag in the canvas, due to the weight of the casualty, bumping on the rungs of the ladder.

DIFFICULTIES ENCOUNTERED AND PRECAUTIONS

5. Care in travelling over debris and erecting ladders may need a certain amount of selective debris clearance. Unsafe floors and/or walls may require shoring. Injuries to casualty will have a bearing on the method of lowering to be adopted. Hospital cases may have to be lowered in their beds. Ladder Drills should be practised as taught. Practice in handling ladders is essential.
(Ref.C.D. Rescue Manual R.S.1)

LADDER SLIDE DRILL - (8 MEN).

RESCUE PARTY 'FALL IN'

Single line - at ease

"Atten-shun" - "Right dress" - "Eyes Front" - "Number" -
"Stand-at-ease".

RESCUE PARTY COMMAND:

- No. 1 Party Leader
- No. 2 Deputy Party Leader
- No. 3 Driver - storeman
- Nos. 4 to 8 Rescue Party Men

DRILL DUTIES FOR LADDER SLIDE:

- Nos. 6, 7 & 8 (Ladder Crew), provide and position ladder.
(Nos. 6, 7 & 8 take positions of ladder crew 1, 2 and 3 respectively.)
- No. 1 Ascends, makes recce, descends, instructs Party.
- No. 2 Ascends with two blankets, (slung over shoulder), prepares and blankets stretcher.
- No. 4 Ascends with 3 x 40 ft. lashings, (hung over arms or slung over shoulder), hauls up stretcher and Head pick-handle.
- No. 5 Attaches stretcher and any other gear to line for No. 4 (clove hitch and half-hitch). Stands by to assist.
- No. 3 Hands out gear from Rescue Vehicle - remains within hailing distance of vehicle.
- Nos. 6, 7 & 8 Re-position ladder for slide, (extend and bring foot out from building.)
- No. 6 Ascends and lashes head of ladder.
- Nos. 2 & 4 Load casualty on stretcher, lash, attach lowering lines, insert Head pick-handle.
- No. 5 Ascends ladder, inserts Foot pick-handle, supports sliding stretcher in descent.
- Nos. 2 & 4 Pay-out lowering lines.
- No. 7 Braces under-side of ladder.
- Nos. 5, 6 & 8 Release stretcher.
- Nos. 5 & 7 Transport casualty - hand over to 1st Aid party and return to Rescue Party.
- Nos. 6 & 8 Re-position ladder.
- Nos. 2 & 4 Descend ladder.
- Nos. 6, 7 & 8 Make up ladder.
- Nos. 3 Makes up equipment, - ropes, etc., - check area for any gear, - check gear on vehicle.

For drill purposes, Rescue Party Men, whilst not engaged in actual work, will stand at ease, facing tower, awaiting orders.

S.A. POLICE DEPARTMENT
EMERGENCY FIRE SERVICES
Police Barracks
THEBARTON

LADDER SLIDE RESCUE DRILL

1. Where the height of a window still permits, a stretcher may be lowered by attaching restraining ropes to the head and tilting it so it slides down an inclined ladder. Pick handles are passed through the stretcher "D's" to facilitate its sliding down the ladder.
2. This method cannot, however, be used when the nature of the casualty's injuries necessitates a stretcher being kept in a horizontal position.
 - (a) The ladder is positioned, extended and placed in position against the building; head of the ladder should be lashed.
 - (b) Two men mount the ladder, taking with them the necessary equipment for dealing with the casualty, who must be blanketed and lashed to the stretcher. In addition, two pick handles for insertion into the "D's" of the stretcher, and at least two 40 ft. lashings, or more if required, according to height.
 - (c) With the casualty securely lashed to the stretcher, the pick handle is passed through the top "D's" of the stretcher, held in position by the restraining lines which, after they have been fastened over the handles and through the "D's" by bowlines, are given a round turn on the pick handles, followed by a half hitch on the handles. Where the opening is narrow, the pick handle may have to be inserted into the "D's" as the stretcher is passed through it.
 - (d) The third man mounts the ladder when everything is in readiness to slide and prepares to receive the foot of the stretcher as it is passed out to him. The other two take up position at ground level, one 'footing' the ladder and the other acting as a human support or brace under the back of the ladder to take part of the strain.
 - (e) The man on the ladder takes a firm grasp of the handles at the foot of the stretcher and eases it gently over any obstructions as he slowly descends, while the men at the top, controlling the restraining lines, can exert added 'lift' to ease the head over such obstructions.
 - (f) When sufficiently near to ground level for the two men to assist, they move round to the sides of the ladder, ready to take charge of the stretcher as it descends, gently lower it to the ground, remove the restraining lines and pick handles and carry the stretcher away.
3. A pick handle at each end of the stretcher is necessary. The lower one to prevent the lower traverse bar from fouling any part of the ladder thus tending to close the stretcher. It also helps to keep the stretcher and lashing off the ladder. The top one enables the stretcher to slide smoothly on the beams of the ladders, but it must be secured with equal projection at each side.
4. These pick handles raise the stretcher off the ladder sufficiently to prevent the sag in the canvas, due to the weight of the casualty, bumping on the rungs of the ladder.

DIFFICULTIES ENCOUNTERED AND PRECAUTIONS

5. Care in travelling over debris and erecting ladders may need a certain amount of selective debris clearance. Unsafe floors and/or walls may require shoring. Injuries to casualty will have a bearing on the method of lowering to be adopted. Hospital cases may have to be lowered in their beds. Ladder Drills should be practised as taught.

Practice in handling ladders is essential.

(Ref.C.D. Rescue Manual R.S.1)

LADDER SLIDE DRILL - (8 MEN).

RESCUE PARTY 'FALL IN'

Single line - at ease

"Atten-shun" - "Right dress" - "Eyes Front" - "Number" -
"Stand-at-ease".

RESCUE PARTY COMMAND:

- No. 1 Party Leader
- No. 2 Deputy Party Leader
- No. 3 Driver - storeman
- Nos. 4 to 8 Rescue Party Men

DRILL DUTIES FOR LADDER SLIDE:

- Nos. 6, 7 & 8 (Ladder Crew), provide and position ladder.
(Nos. 6, 7 & 8 take positions of ladder crew 1, 2 and 3 respectively.)
- No. 1 Ascends, makes recce, descends, instructs Party.
- No. 2 Ascends with two blankets, (slung over shoulder), prepares and blankets stretcher.
- No. 4 Ascends with 3 x 40 ft. lashings, (hung over arms or slung over shoulder), hauls up stretcher and Head pick-handle.
- No. 5 Attaches stretcher and any other gear to line for No. 4 (clove hitch and half-hitch). Stands by to assist.
- No. 3 Hands out gear from Rescue Vehicle - remains within hailing distance of vehicle.
- Nos. 6, 7 & 8 Re-position ladder for slide, (extend and bring foot out from building.)
- No. 6 Ascends and lashes head of ladder.
- Nos. 2 & 4 Load casualty on stretcher, lash, attach lowering lines, insert Head pick-handle.
- No. 5 Ascends ladder, inserts Foot pick-handle, supports sliding stretcher in descent.
- Nos. 2 & 4 Pay-out lowering lines.
- No. 7 Braces under-side of ladder.
- Nos. 5, 6 & 8 Release stretcher.
- Nos. 5 & 7 Transport casualty - hand over to 1st Aid party and return to Rescue Party.
- Nos. 6 & 8 Re-position ladder.
- Nos. 2 & 4 Descend ladder.
- Nos. 6, 7 & 8 Make up ladder.
- No. 3 Makes up equipment, - ropes, etc., - check area for any gear, - check gear on vehicle.

For drill purposes, Rescue Party Men, whilst not engaged in actual work, will stand at ease, facing tower, awaiting orders.

1965

S.A. POLICE DEPARTMENT
EMERGENCY FIRE SERVICES
Police Barracks
THEBARTON

E.F.S./CIVIL DEFENCE

LADDERS - HANDLING AND TESTING

INTRODUCTION

1. Ladders play an important part in rescue operations and it is essential that their construction and uses should be fully understood. Ability to handle and move ladders quickly and safely is an indication of good training and will ensure freedom from accidents, and maximum efficiency.

Each Rescue Section vehicle is issued with (a) two short ladders, which can be coupled, (or one short extension ladder of two sections), and (b) a 35-ft (maximum) extension ladder.

SHORT LADDERS

2. (a) Two short ladders each 8 feet long coupled together form a ladder approximately 13 feet long. A ladder of this size can reach first-floor windows of most dwelling houses and also into basements, and will prove valuable when making a reconnaissance.
- (b) Care must be taken that the reinforcement of the ladder is always on the underneath side of the load, and that firm foundation is found for the bottom of the ladder. In some cases it may be necessary to tie or anchor the bottom; and at other times the top of the ladder may have to be fastened, when one man must "foot" the ladder until the top has been secured. If an anchorage for top or bottom of the ladder is not practicable, the ladder must be footed while in use.
- (c) These short ladders may also be employed when getting over obstacles, damaged walls, gaps and so on. For bridging a gap, ladders can be used by placing one (or two side by side) over the opening (reinforcement if any, on the underside) and laying a board or boards on the rungs. Where possible, one length of board should be used on one ladder, but if this is not practicable, care must be taken to overlap the ends of the boards where they meet in such a way that the rescuer will not trip when carrying a casualty. The ladder or ladders must be long enough to bridge the gap and to have adequate support at either end.
- (d) These ladders must be examined periodically for excessive wear or damage.

EXTENSION LADDERS, 35 FEET (See also EFS/CD No. 4/7)

3. The normal issue is the 35-foot extension ladder which is in two sections, the upper section sliding on and between the sides of the lower section. Pawls are fitted to the lower end of the sliding section and operate on a rotating shaft; pulling lines are taken through sheaves fixed near the top of each string of the lower section, brought down and fastened to hooks or cleats at the bottom of this ladder, one cheat being attached to the pawl shaft, thus providing endless lines by means of which the top section can be extended, and the pawls which are mounted on the sliding section can be engaged and tripped or released. The metal tongues fitted to the top section of the ladder slides into grooves cut in the strings of the bottom section.

EXTENSION LADDERS 35-foot Cont:-

To make it easily distinguishable in the dark the strings of the bottom section should bear a white line to indicate the "limit of safety" when extended for use - the overlap of the ladders is normally five rungs. Similarly the "bottom" of the ladder should have a 6-inch band of white paint. The ladder is strengthened on the underside of all strings by galvanised wire which is stretched tautly in the groove along the edge of the strings, being secured at the head and foot and kept in position by staples. The ladders are further strengthened by cross-ties of wrought iron rod from string to string at intervals. Ladders should not be painted as paint would hide incipient defects. Clear varnish or treating the bare wood with linseed oil usually proves satisfactory.

STANDARD TEST OF 35-FOOT EXTENSION LADDER

- (a) Extension ladders should be tested monthly or more often if necessary. The first test is a visual examination, followed by a practical test of the strings and rungs.
- (b) Examine the condition of the strings, rungs, pulleys and pawls and lubricate working parts, (keep lubricant off extending rope.) Look for obvious defects, especially any displacement of anchoring of reinforcing wires, cracks or shakes in the strings or rungs, loose rungs or missing wedges, riveting of cross ties and position of washers, bent or twisted pawls or pawl shaft, bent cleats, loose guides, frayed ropes, and defective fastenings of ropes to pawl shafts. Pay particular attention to the condition of the strings at the bottom of the lower half of the ladder.
- (c) If the examination is satisfactory, lay the ladder flat on the ground with the strengthening wire on the strings towards the ground; extend it to the length shown by the white marking lines on the main ladder, lift it on to two trestles (or boxes, etc.) positioned about two feet from either end; measure the distance of a point in the middle of the span from ladder to ground.
- (d) A man approximately 12 stone should sit gradually on the centre of the ladder, after it has reached its limit of sag he should spring smartly off, when the ladder should resume its previous position. If there is a discrepancy between the first and second measurements, further inspection should be made, paying particular regard to the anchoring or stretching of the reinforcement. If it appears that serious stretching has taken place in the reinforcing wire, or other defects becoming apparent during this test, the ladder should be returned to store.
- (e) To test the extending rope, the ladder is erected in its closed state against a wall, two men grip a rung of both the upper and lower sections together to prevent any sliding movement whilst two men endeavour to extend the ladder by pulling on the rope. If the rope proves to be sound, the ladder is extended to its full height and two men again apply their weight to the rope.
- (f) After this test, the ladder should be halved (see paragraph "Halving Ladders") and each half raised so that the weakest parts of the rungs and sockets may be tested. Each rung should be "Jumped" by a man who has ascended the ladder. The correct method is to transfer the man's weight sharply downwards from each rung to the next with the feet separated as far as the strings will permit. The height of the jump should not be increased nor used to deliver a violent blow to the rung. The ladders should be erected as nearly vertical as safety conditions permit, the head being secured and two men stationed at the foot. The ladders should be reversed and the remaining rungs "jumped".

ANGLE OF LADDERS WHEN RAISED

4. When a ladder is raised the angle which it makes with the ground should not be too great or too acute. As a general rule the foot of the ladder should be placed at a distance from the base of the wall about equal to one quarter of the height to be reached and the ladder should be extended so that the head of the ladder should not be less than 4 feet above the stepping-off point. This would mean that to reach a stepping-off point 28 feet above the ground, the foot of the ladder from the wall should be 7 feet from the wall. The distance of the foot of the ladder from the wall should never be more than half the height to be reached.

SECURING THE HEAD OF THE LADDER

5. When it is necessary to secure the head of a ladder, this may be done with a lashing line or piece of sashcord. The usual method is by tying it to a piece of timber which is long enough to spread across and inside the width of the window opening.

ANCHORING THE FOOT OF THE LADDER

6. This may be done by means of fastening to an improvised picket or pickets, or tying back to any secure object behind the ladder, e.g., railings, gateposts, etc.

LADDER CLIMBING

7. The ladder should be climbed steadily, keeping the body erect, the head upright, the arms straight but not tense, without any tendency to hug the ladder, and the hands grasping the rungs at a level between waist and shoulders. It must be remembered that the legs and not the hands carry the weight of the body when climbing, and at each step the ball of the foot, not the arch, should be placed on the rung.

HALVING THE LADDERS

8. (a) In some cases the complete ladder may not be required, or two lengths equal to the length of each section of an extension ladder may be called for, and this can be achieved by halving the ladder - i.e., by removing the sliding extension from the main ladder.
- (b) The ladder should be first placed on the ground, the sliding extension uppermost. The method of halving as follows; with the ladder lying on the ground, the ropes are uncoupled from the hooks or cleats, the pawls freed and the upper extension withdrawn. To reassemble, the upper extension is placed between the strings of the main ladder and pushed forward into its correct position; the ropes are re-connected to the cleats, pawls are placed in position on the lowest rung of the main ladder.

(Reference Civil Defence Manual, R.S. 6)

S. A. POLICE DEPARTMENT
EMERGENCY FIRE SERVICES
Police Barracks
THEBARTON

E.F.S./CIVIL DEFENCE

LADDERS -- SHORT - EXTENSION - DRILL
(2 MAN - 1 MAN)

Nos. 4 and 5 of the Rescue Party normally carry one short ladder each. Unless otherwise instructed, No. 4 will carry the Top Section and No. 5 the Bottom Section.

The Bottom Section has a steel brace bar fixed to the upper side head.

The Top Section has side brackets fixed to the outside bottom strings and the pawls hinged on a 3/8 inch tie rod at the base.

DRILL - 2 MAN:

- No. 5 Supports bottom section in erect position, base on ground brace bar outwards, (away from body).
No. 4 Facing No. 5 supports top section in erect position, base on ground, pawl tie rod inwards (towards body).
No. 5 Lifts ladder, slips bottom strings through side brackets of top section - then brace bar over head of top section.
No. 4 Extends ladder by grasping base of strings top section - left and thrust to high enough - ensure pawls engaged.
Nos. 4 and 5 Place one foot on bottom rung as soon as pawls are clear, to foot ladder.

Ladders should be footed, lashed at the head, or anchored when in use.

TO "STRIKE" LADDERS:

- No. 5 Inside position assisted by No. 4 (outside) raise ladder to erect position, on strings.
No. 4 Trips pawl by thrusting on base of top section strings, support with one hand, grasp pawl tie rod with other hand, lower to ground.
Nos. 4 and 5 Foot ladder on bottom rung.
No. 4 Lift top section by strings to engage pawl on bottom rung. Should ladders require to be separated, reverse procedure of engaging ladders above.

DANGER! - Particular care should be taken to keep fingers and hands clear of rungs when raising or lowering extension. No. 4 to take care not to let top section slip.
Fingers and hands are especially vulnerable to injury with these ladders.

P.T.O.

DRILL - 1 MAN:

TO ENGAGE LADDERS:-

Place Top Section on ground, pawl tie rod downwards.
Slip Bottom Section into side brackets then brace bar.
Elevate ladders and engage pawls on bottom rung.

TO EXTEND:-

Support ladders by strings in erect position, canted slightly towards body, with pawl tie rod towards body. Lift top section by grasping strings and place foot on bottom rung. Extend by grasping base of strings - lift and thrust to high enough - ensure pawls are engaged.

TO "STRIKE" LADDER:-

Reverse action of extending.

AGAIN - CARE WITH FINGERS AND HANDS!

-----oOo-----

S.A. POLICE DEPARTMENT
EMERGENCY FIRE SERVICES
Police Barracks
THEBARTON

E.F.S. - CIVIL DEFENCE

LADDER, EXTENSION 55 ft. - 3 MAN DRILL, 2 MAN DRILL AND
1 MAN DRILL.

DUTIES: THREE MAN DRILL

- No. 1 Carries head of ladder, under-runs (elevates), extends and pawls ladder.
No. 2 Attends to foot of ladder in carrying and positioning. Foots ladder.
No. 3 Assists with carrying ladder only when necessary. Under-runs (elevates) ladder. Take charge of operations, giving such orders as required to ensure efficient and safe operation.

DRILL:

For drill purposes, the ladder will be placed a convenient working distance from the building (20 paces) with the foot of ladder facing the building - top section of ladder uppermost.

Crew to fall in, single line, standing at ease, two (2) paces from head of ladder facing building.

Instructor takes up a position near building, facing ladder crew and gives orders.

"LADDER CREW - ATTEN-SHUN" : "RIGHT DRESS (Close interval)" : "EYES FRONT" : "NUMBER" : "LADDER CREW - TAKE POST".

- No. 1 Right side head of ladder
No. 2 Left side foot
No. 3 Left side centre of ladder
Drill to be carried out smartly.

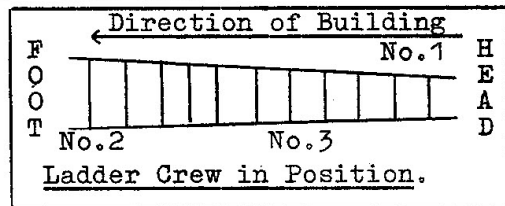

TO GET TO WORK:

Instructor details action to be taken then gives order "LADDER CREW - GET TO WORK." This command may be given by one blast of a whistle.

1st Movement:

Nos. 1 and 2 lift ladder by grasping 2nd rung from head and foot respectively and carry ladder to scene of operation. (The ladder may also be carried on the shoulders of 1 and 2 or in any way practicable to suit fire ground conditions.)

No. 3 proceeds with ladder crew, only assisting when required. (In practice, No. 3 would clear obstructions and track for Nos. 1 and 2 and assist with carrying, if necessary.)

2nd Movement:

Nos. 1 and 2, on reaching suitable working position close to building approximately three (3) feet for drill purposes turn ladder over. No. 2 places foot of ladder on ground.

No. 2 foots ladder (by standing on bottom rung or with feet against bottom(s) of strings), grasps convenient height rung, sits back to counter balance ladder.

3rd Movement:

Nos. 1 and 3 under-run ladder (elevate) on strings to erect position with ladder finishing in position slightly canted towards the building.

4th Movement:

No. 1 extends ladder by hauling on pawl rope (if ladder is fitted with two pawl ropes, No. 3 hauls on other rope.)

No. 3 takes charge, gives any orders required for safe and efficient operation. Gives order "HIGH ENOUGH" when desired height is reached.

No. 1 pawls ladder.

Nos. 1 and 3 bring foot of ladder away from building to correct working distance. (For general purposes, quarter of height is satisfactory, but for "Stretcher Slide" the foot required to be taken further out. See EFS/CD. No. 4/8.)

N.B. The ladder should be made secure by lashing head, anchoring base, or otherwise constantly footed whilst in use.

When it is not convenient to site foot of ladder near building and ladder has to be "lowered" against building; No. 2 lowers ladder by walking back, supporting ladder strings on rungs, No. 1 foots ladder, assisted by No. 3 for this lowering operation.

TO STRIKE LADDER: (Lower and Make-up Ladder)

No. 3 gives order "STRIKE LADDER".

Nos. 1, 2 and 3 return foot of ladder close to building. Elevate head from building. Nos. 1 and 3 foot and support ladder from outside, No. 2 foots and supports ladder from inside (back to building).

No. 1 extends ladder, trips pawls, lowers extension.

Nos. 1 and 3 lower elevation by under-running ladder on strings. No. 2 foots ladder.

Turn ladder over with top section upper-most.

Return ladder to original drill position or appliance. Ladder crew fall out at head of ladder in original positions. Instructor gives order "LADDER CREW - FALL OUT."

DUTIES: TWO MAN DRILL

No. 1 Handles head of ladder, elevates (under-runs on rungs), extends, pawls ladder.

No. 2 Foots ladder (by standing on bottom rung or with feet against bottom(s) of strings), grasps convenient height rung, sits back to counter balance ladder.

N.B. When ladder is heavy and circumstances permit, place foot of ladder against building and both men elevate by under-running ladder on the strings.

Ladder is positioned as for 3 MAN DRILL.

TO STRIKE LADDER:

Both men return foot close to building (about 3 feet), elevate head from building, taking care to maintain balance.

No. 2 then foots and supports ladder from inside.

No. 1 extends ladder, trips pawl, lowers extension, lower elevation of ladder by under-running on rungs.

No. 2 foots ladder.

Turn ladder over with top-section upper-most.

Return ladder to original drill position or appliance.

ONE MAN DRILL:

Ladder man places foot of ladder against building, elevates, (under-runs hand over hand on rungs), bring foot away from building (about 1 foot), extend, taking care to maintain ladder in balance, canted slightly towards building. Pawl ladder bring foot suitable working distance from building and anchor. To Strike Ladder, reverse the procedure.

GENERAL FIREMANSHIP AND SAFETY HINTS FOR LADDER HANDLING:

WATCH THE HEAD OF THE LADDER WHEN ELEVATED to maintain its balance. A ladder out of balance is soon out of control and liable to cause injury to personnel and damage to property.

The officer in charge should maintain a close observation of all movements - take positive command, and on noticing any action or fault which may endanger his crew or cause unnecessary damage to equipment or property, should call "STILL". On the order "Still" ladder crew stop immediately, be alerted to danger, and await further orders.

When ground crews are working in conjunction with crews above, attention should be paid to any commands from above. When any equipment is being lowered by line a warning command to those working below should be given by saying "STAND FROM UNDER". Upon hearing this command, the ground crew should stand clear immediately. This command should also be given when any rubble, etc. is dropped to the ground. On no account should anything be dropped until it has been ascertained that those on the ground are standing clear and are alert to any danger. HELMETS SHOULD BE WORN AT ALL TIMES WITH THE CHINSTRAP DOWN!

CLIMBING:

The ladder should be climbed steadily, keeping the body erect, the head upright, the arms straight but not tense, without any tendency to hug the ladder, and the hands grasping the rungs at a level between waist and shoulders. It must be remembered that the legs and the hands carry the weight of the body when climbing, and at each step the ball of the foot, not the arch, should be placed on the rung.

At least one rung should be grasped by hand at all times when on the ladder unless a "leg lock" is taken, i.e. to pass one leg over a rung to make a firm "lock".

In transporting or lowering equipment from buildings, it is safer to use a hauling line than to attempt to carry up and down the ladder unless the gear can be slung on the shoulders or back, leaving both hands free for safe climbing.

S.A. POLICE DEPARTMENT

EMERGENCY FIRE SERVICES
Police Barracks
THEBARTON

HAULING AND LIFTING EQUIPMENT

- TIRFOR -

1. The object of this Circular is to introduce the 'TIRFOR'.
2. (a) With the vast areas of damage which we could be confronted in the event of a nuclear disaster it is essential for rescue parties to be equipped with a portable, versatile and adaptable machine.
(b) The Tirfor has these attributes and by virtue of its lightness can be carried forward from the rescue vehicle over debris without seriously impairing the men's efficiency for their life saving task.
(c) The appliance consists of a machine or casing through which passes a long steel cable which is attached to the load to be hauled or lifted. The operation of a lever handle backwards and forwards pulls the cable through the machine, which, if properly anchored, causes the load to be hauled towards the machine.
3. The equipment consists of:
(a) A pulling and lifting unit complete with a swivel hook to enable it to be secured.
(b) A detachable telescopic tubular steel handle for operating the unit.
(c) A length of flexible steel wire rope 60 feet long, 7/16 in. diameter, fitted with a hook at one end, the other end being tapered and fused. This rope is coiled onto a reeler for convenience in carriage.
4. The machine unit consists of a steel casing enclosing two pairs of automatic jaws which grip the cable passing through the casing. These two pairs of jaws are moved in opposite directions by means of linkage when the handle is operated backwards and forwards.

Forward and Lifting Movement.

5. When the handle is put on the lever at the side of the casing and is moved towards the hook, the pair of jaws fixed to the crank shaft move in the same direction, gripping the cable and carrying it forward. Simultaneously the other pair of jaws, actuated by connecting rods fitted on the same crank shaft, moves away from the hook, sliding along the cable.
6. When the handle is moved in the opposite direction, the pair of jaws fixed to the crank shaft moves away from the hook, sliding along the cable, while the other pair of jaws moves forward in its turn gripping and carrying the cable in the same direction as before and pushing it through the first pair of jaws in which it slides, and so on. The alternating operation of the handle results in a hauling or lifting movement of the cable of about 2½ in. for each complete forward and backward stroke of the lever, which with normal operation on a light load results in travel of about 11 feet 6 inches per minute.
7. This unit provides a mechanical advantage of 1:43. Its size is 24 ins. x 12 in. x 6 in. wide and it weighs 39 lbs. Its S.W.L. (safe working load) capacity is:- pulling up to 30 cwts., lifting up to 20 cwts.

Reverse of Lowering Movement.

8. By transferring the operating handle to the lever on the top of the casing, a reversing action is obtained. This passes the cable through the machine in the opposite direction and enables the load to be lowered. The cable is under constant tension while the load is on it and does not jerk or slip during the lowering. Any jerky movement will be due to lack of lubrication, a fault which should be rectified immediately.

9. The following operating instructions are those issued by the manufacturers of the machine:

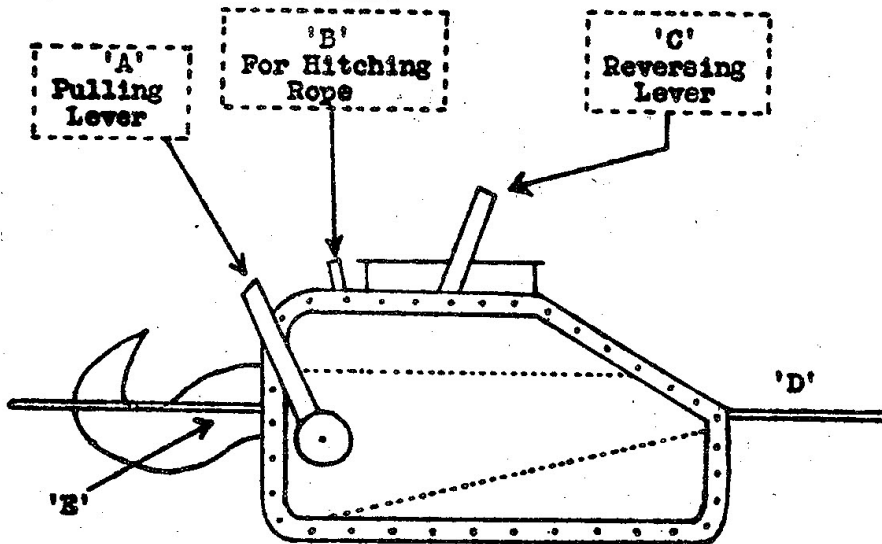

- (1) Pull lever 'B' firmly towards hook on machine, until it is seated in the notch.
- (2) Push the rope into the machine at 'D' until it protrudes through the hole in hook at 'E'.
- (3) Pull the rope through the machine until the desired length is reached.
- (4) Place lever 'B' back into the operating position - this is done by lifting the lever out of the notch and allowing the spring inside the machine to carry it into its operating position.
- (5) The rope is now firmly gripped in the jaws of the machine. To pull the rope through the machine, place telescopic operating handle on lever 'A' and move it along the direction of the rope. The rope moves through the machine on both forward and backward strokes of the lever.
- (6) To reverse rope through the machine, remove the telescopic handle from 'A' and place it on lever 'C' and move it again in the direction of the rope. The rope is paid backwards through the machine on both strokes of the lever.
- (7) To remove rope, pull lever 'B' towards hook as in (1) and pull rope through the machine.
- (8) If the operator cannot move the load with the telescopic operating handle fully extended, the load is too great for the machine, and the snatch block supplied should be used to increase the machine's power.
- (9) Always use slings of sufficient strength to withstand the load.

- (10) Keep the wire rope wound onto the reeler when not in use.
- (11) Never allow any kinks in the rope to enter the machine as this causes internal damage.
- (12) Only use the wire rope supplied with the machine.
- (13) Do not leave the rope release lever 'B' in its release position when the machine is not in use as this will shorten the life of the springs.
- (14) Never operate 'A' and 'C' at the same time as this will cause internal strain.
- (15) Never anchor the machine by the tip of the hook, always use a sling.

Lubrication.

10. (a) Heavy gear oil should be poured into the slot at the top of the machine. The machine should then be shaken to allow the oil to reach all working parts, the surplus oil being drained off through the rope holes.
- (b) Oil regularly through the oil holes which are situated on both sides of the lever shaft 'A'.

Maintenance.

11. (a) Before using the machine:
 - (i) Check wire rope to see that it is free of kinks and broken wires. Never use a damaged rope as this jams inside the machine.
 - (ii) Put rope in machine and move it to and fro with levers 'A' and 'B'; this movement should be easy and free from jerks.
 - (iii) Make sure that the machine is lubricated correctly.
- (b) When using the machine:
 - (i) Should the machine become filled with dirt or dust from the debris it must be immersed in a bath of kerosene and shaken well. This operation must be repeated until the dirt or debris dust is removed. The machine must be well lubricated before use.
 - (ii) Should the machine become jammed with small pieces of dirt or debris dust, the casing bolts must be removed and one half of the casing should be lifted off. The dirt or debris can be scraped out of the machine. When the casing is replaced ensure that the cross bar on the spring tubes always fits properly into the slots on both casings. This can be done by looping a piece of wire round the bar and holding it in position until the bolts are fitted. Ensure that the hook and rope entry guide are fitted. Make sure that all nuts and bolts are replaced and properly tightened.
 - (iii) Should the motion become jerky when lowering, this is due to lack of lubrication and the machine should be oiled immediately.
- (c) After using the machine:

The wire rope must be coiled back onto the rope reeler.
- (d) Examinations at monthly intervals:
 - (i) Check for wear or misuse.

- 11.(d).(ii) Makes sure that the rope hook is properly fastened on the rope.
- (iii) Measure distance 'X' on rope hoop and anchoring hook; if it is more than $2\frac{1}{2}$ in. the hook has been strained and should be replaced.

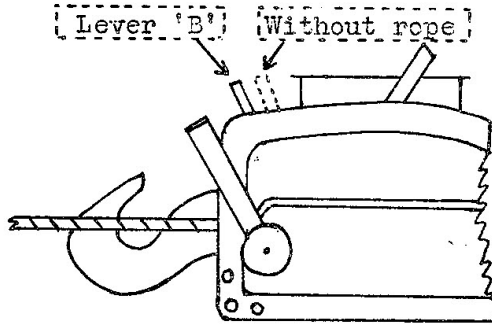

- (iv) Make sure that the nuts and bolts on the casing are fitted and properly tightened.
- (e) Monthly check on wear of machine jaws:
- (i) Remove wire rope from the machine and let the release lever 'B' return to its normal position.
 - (ii) Mark this position on the casing.
 - (iii) Pull lever 'B' forward into its groove, and feed rope into the machine.
 - (iv) Return lever 'B' to its normal position with the rope in the machine, as though the machine was about to be used.
 - (v) Mark the new position of lever 'B' on the casing.
 - (vi) There will now be two marks on the casing. The distance between these should never be less than $\frac{1}{2}$ in; if less it is a sign of excessive wear on the jaws and these should be replaced.

Operational Uses

12. As a device for lifting or hauling, the machine has innumerable uses and applications. Being light and compact it can be attached to any convenient holdfast or hung from overhead beams, or girders, slung from or attached to derricks or sheer legs, or even attached to the load itself, if the cable end is anchored to an immovable object.

13. The 60 feet cable enables the load to be lifted, lowered or hauled considerable distances without changing the position of the machine, and in conjunction with the snatch blocks, permits the most convenient position to be selected for fastening the machine, while the rope can be taken over the pulleys, through window or door openings or down through floors to wherever the load may be. It can also be passed over a block at the head of a derrick or sheers to obtain height for raising loads, such as blocks of masonry or for erecting tall poles or posts.

Anchoring the Machine

14. The efficiency, and indeed the safety of all applications of the hauling and lifting machine depends upon the security of the anchorage or holdfast. This may be anything sufficiently strong or immovable, but it must be firm enough not to show signs of failure under load.

15. Secured near the base of stout posts, lamp standards, stanchions, bollards, etc. by means of wire bonds, the machine will be able to haul in its cable and move, lift or lower its load without fear of sudden failure.

F.L. KERR,
Director, Emergency Fire Services.

HYDRAULIC RESCUE EQUIPMENT.

The Requirement

1. A very high proportion of all rescue tasks will, in the main, consist of opening voids or survival points where people are trapped inside. There are many ways in which the job can be done, but one of the simpler ways is to force the components of the void apart and thus provide a means of access.

New Equipment

2. In the past, this technique has been carried out with either a heavy house lifting jack or a very heavy lever. The more modern practice is to employ the tremendous mechanical advantage which is now available in the shape of a ram or one of two spreader attachments which can be coupled to a standard type of hydraulic pump. The power per weight of equipment can be readily appreciated by the fact that a pump and ram weighing approximately 20 lbs. can lift a load of 10 tons.

Contents of Kit

3. The Hydraulic Rescue Kit consists of the following major items:

2 x Hydraulic Pumps	1 x Alligator spreader
2 x 6ft. lengths of pressure hose	2 x Flat base plates
2 x Rams of 10 ton capacity	2 x Ram toes
2 x screwed adaptors for Rams	2 x Plunger toes.
1 x Wedge spreader	

It will be noted that each set has two basic jacking units, i.e. two pumps and two rams and the various fittings for each ram. In addition there is provided one wedge spreader and one alligator spreader. The reason for this is that there will be a number of jobs where two jacks working simultaneously will have to be used, but relatively few occasions where two of the same type of spreader are required together.

Method of Operation

4. The apparatus is operated by oil pressure from the pump through one, or more, lengths of hose to the ram and its accessories, or to the spreaders.

The various items comprising the kit can be connected or disconnected by finger operated screw couplers. No tools are required. When the lifting or spreading attachment has been coupled to the hose, power is applied simply by operating the hand lever on the pump.

NOTE: If undue force has to be applied to the operating handle when the ram or spreaders are near the end of their travel, cease pumping immediately otherwise damage to the equipment may occur. The Australian pump has an inbuilt relief valve, but too much reliance should not be placed upon it, especially when using either of the spreaders or when the ram plunger is near the end of its travel.

The Components

5. Pump: Hand operated, normal working position flat on floor with foot on foot plate, can be used in any position except with oil reservoir pointing downwards, i.e. hose connection uppermost. Operating lever has metal clip to secure it in position so lever may be used as a carrying handle.

On the right hand side of the pump is located the release valve wheel. This must be tight when the load is being lifted and unscrewed a couple of turns when the time comes for the ram or spreader to be closed up. Lowering can be very finely adjusted by use of this wheel.

On the head of the pump is also located the relief valve. This only operates when the weight lifted by the ram (and only the ram) exceeds the safe working load of the equipment, i.e. 10 tons. When a marginal load is being lifted on the ram this valve should be carefully watched - any flow of oil from it indicates the load has been exceeded, and an alternative means of lifting must be found, e.g. the use of two pumps and rams on the same job.

6. Ram: This is simply a compact metal cylinder weighing about 5 lbs. out of which extends a metal plunger when oil is pumped in under pressure. When closed up the overall height is $4\frac{3}{4}$ ins. full extension is $6\frac{3}{4}$ ins. Although this lift seems extremely small, it does enable the ram to be operated in very confined spaces initially, and by the normal process of packing as the operation proceeds an 8 to 10 inch opening can be rapidly achieved. Using the ram itself on a vertical lift, 10 tons is the limit. If, however, the base plate and ram toe or the plunger toe and ram toe are being used, a load of not more than 5 tons should be applied. This is because the load is being lifted on one side of the central axis and a bending movement is set up in the ram.

7. Hose: 6 ft. lengths with a male coupler at one end, and a female coupler at the other. Hoses are interchangeable and are pre-charged with oil ready for immediate use. A slight seepage of oil is of no consequence when couplings are being made or broken. Great care should be taken to ensure inner washers are not displaced or lost and that no dust or grit enters the system when coupling up.

8. Ram Toe, Plunger Toe, Base Plate, Screwed Adaptor and Serated Saddle: The serated saddle is the normal head for the plunger. It is simply a push fit into the hollow shaft of the plunger and is interchangeable with the screwed adaptor. The thread on this adaptor will screw into either the plunger toe or base plate; with the base plate fitted and the ram inverted the load to be lifted is spread over a much wider area.

The ram toe is a collar which screws on the top of the ram cylinder and has a lifting lug projecting from it. When used in conjunction with the base plate, jacking can commence from an opening about 2 inches high, instead of the $4\frac{3}{4}$ inches required for the straight ram.

The plunger toe screws onto the screwed adaptor and when used with the ram toe provides a very useful type of spreader.

Experience will dictate which one of these many combinations is the correct one for the job.

9. Wedge Spreader: Where clearances for operating the ram are nil, this wedge can be carefully driven in and then power applied to it with the pump. An initial lift of about $2\frac{1}{2}$ inches can be achieved but the weight at the tips of the wedge must not exceed 15 cwt.

10. Alligator Spreader: This screws onto the top of the ram body and is an enlarged version of the wedge. When fitting, the serated saddle is removed from the ram and the push rod of the alligator spreader inserted into the hole in the ram plunger. This is important. Check and see that it is so.

When closed, the spreader requires an opening of $1\frac{1}{4}$ inches, but has a maximum opening of 1 foot. The weight on the tips of the jaws should not exceed 1 ton.

Maintenance

11. Oil Check: From time to time the oil level in the pump should be checked. This is done by holding the pump vertically and removing the screw at the rear of the oil reservoir. A dip stick is attached to the screw and if necessary, oil should be added to bring the level up to the notch on the stick. Do not over fill as air space must be left in the reservoir to allow the pump to function.

NOTE: Only good quality Hydraulic Jack Oil should be used for topping up. Hydraulic Brake Fluid or engine oil should NOT be used. However, in cases of extreme emergency, any non-viscous liquid can be used. e.g. SAE 10 motor oil, or even water. If this has occurred, the entire system should be drained at the earliest opportunity.

12. Air in the System: Should air get into the system it will not function effectively. Difficulty will be encountered in getting the ram or spreaders to extend or hold their extended position. Air should be expelled in the following way:

- (i) Connect ram to pump and fully extend it.
- (ii) Open release valve.
- (iii) Invert ram and push down on plunger until fully collapsed.
- (iv) Close release valve.
- (v) With pump vertical (hose end downwards) give 8 to 12 rapid strokes.

Repeat the procedure, if necessary.

13. Blank Caps: Whenever any item of kit is not in use, the blank cap should be screwed into the coupler to protect the valves from dirt or grit.

14. Accessories: Apart from keeping all screw threads clean and oiling the moving parts of the wedge and alligator spreaders, no maintenance is called for.

Special Features of the Equipment

15. The entire kit is very light and portable considering the fact that the two rams have a combined lifting capacity of 20 tons.

16. The pump permits very selective control over lifting and lowering.

17. The flexible hose allows the power tools (ram and spreaders) to be operated in a position that may be inaccessible for normal type jacking equipment. It also allows the operator to keep well clear of the actual job.

18. The ram and spreaders will work upside down, sideways, any way. They are still equally effective.

19. It is important to realise that the hydraulic rescue set is not only an extremely efficient lifter, but is also just as an effective pusher.

Conclusion

20. The purpose of this Circular has been to outline the need for, and the use of the hydraulic rescue kit. It is pointed out that no attempt has been made to give detailed information as to how the equipment is used in the infinitely variable field of rescue work. Practical training is essential if the rescuers are to become completely familiar with the wide range of problems the hydraulic rescue kit can solve.

S.A. POLICE DEPARTMENT
EMERGENCY FIRE SERVICES
Police Barracks
THEBARTON

E.F.S./CIVIL DEFENCE

THE REMOTE BREATHING APPARATUS

INTRODUCTION

1. The remote breathing apparatus issued to the Rescue Section has been designed to impose the minimum amount of restriction on the wearers movements; consequently he can effect more speedily the rescue of casualties from localised areas, where there is a high concentration of coal gas, or industrial gases against which the General Service respirator gives inadequate protection, or a deficiency of oxygen, such as may be found in damaged basements or under smouldering debris. Under certain circumstances, the presence of large quantities of irritant smoke may also necessitate the wearing of the remote breathing apparatus.

The equipment consists of:-

- (a) A service respirator facepiece, and haversack, with a long flexible connecting tube coupled by means of a hose union to a 40-ft length of 1-inch internal diameter wire bound rubber hose; the flexible connecting tube has a small canvas bucket attached to it a mid-length. This is fitted with a hook or cord to enable the connecting tube to be fastened to a buttonhole in the wearers clothing to prevent the tube catching in obstacles with the consequent risk of displacement of the facepiece.
- (b) A 6-ft. length of sash cord is attached for securing the union end of the 40-ft. hose length to the body of the wearer.
- (c) A signalling line for attaching to the wearer.
- (d) A respirator canister connected to the 40-ft. hose.

This equipment calls for a team of three for its operation:-

No.1 - the wearer and rescuer.

No.2 - who holds the signalling line.

No.3 - who is responsible for the haversacks and pays out the coil of hose.

If possible, a fourth man should be standing by with a second set of R.B.A. equipment at the ready, should the rescuer require assistance. Even if the man is not available the second set of equipment must be kept close handy.

During the rescue operation, No. 2 keeps as close to No. 1 as practicable and assists with the paying out and hauling of the hose. He normally shouts instructions to No. 1 and awaits his signals by pulls on the signalling line. No. 3 is responsible for paying out the hose and seeing that the respirator container is clear of the ground and in fresh air.

ASSEMBLY AND STOWAGE

2. The flexible connecting tube of the respirator facepiece has a male hose union fitted at the end. This is connected to the female union at one end of the 40ft. hose, care being taken to ensure that, when assembling, the washer is in place within the female coupling.

The 40-ft. hose is secured to the right rear side of the wearer by means of a 6-ft. length of sash cord. The cord is middled and a clove hitch formed around the union, joining the respirator breathing tube to the 40-ft. hose.

- 2 -

2. ASSEMBLY AND STOWAGE ~ Cont:-

A bowline is placed on one end, the other end passing around the waist of the wearer, through the bowline and made off with two half hitches. (The bowline allows apparatus to be rapidly removed, should the need arise.)

The apparatus should be assembled permanently ready for immediate use, the facepiece and the container stowed in the haversack and the length of hose, with the cord attached, coiled.

FITTING

3. It is important to note that full protection will only be obtained if the facepiece is properly fitted to the face of the wearer. The head harness should therefore be adjusted so that a correct fitting is obtained for the two members of the party who will normally wear the apparatus, and it should be ensured that the correct fitting has been obtained, preferably by testing the apparatus in a gas chamber as a depot routine measure. Operationally the wearer will, immediately after putting on the facepiece, himself test the fit for gas tightness by squeezing the corrugated tube to cut off his air supply.

SIGNALS

4. Under normal conditions it should be possible for the rescuer to hear orders shouted to him from outside, and in most cases he, by shouting into his facepiece, can communicate with the No. 3 man paying out the hose. It is important, therefore, that this man keeps the container close to his ear.

If this means of communication with the rescuer is not possible it is imperative that the attendant No. 2 pays careful attention to any pull he may receive on the line. In some cases it may be difficult to distinguish the difference between deliberate signals and normal or accidental pulling on the line during the rescue operation. If in doubt the No. 2 man should shout to No. 1 for a repetition.

The following are the two signals which should be made by No.1:-

Three distinct pulls - haul in air hose.

A series of rapid jerks (not less than five) - I need assistance.

PRECAUTIONS

5. Every member of the Rescue Section must be trained in the use of this apparatus. Whenever one man is using a set, a second set must always be held in reserve at instant readiness (two sets are carried on each Rescue Vehicle) with the second rescuer wearing it, apart from putting on the facepiece, in case the first man requires help. If both sets are in use, a third should be obtained from another Rescue Party or sent for as a stand-by.

PRACTICE DRILL

6. It is suggested that practice in the following drill for utilising the apparatus will enable rescuers to make the best of the apparatus, if and when the need arises for its use. The team consists of three men, Nos. 1, 2 and 3, whose principal duties have already been outlined.

No. 1 places cord around his waist (assisted by No.3) and makes it fast. He then removes the facepiece from its haversack and hands the haversack to No.3. Next he makes fast the flexible connecting tube from the facepiece against his chest by securing the hook or cord (which is found attached to the small canvas bucket half-way down the tube) to a convenient buttonhole of his clothing.

He then secures his signalling line around his waist using a bowline.

PRACTICE DRILL - Cont:-

No.3 holds the container and pays out the hose (assisted by No.2 if possible).

No.2 ensures that the signalling line is securely tied around the waist of No.1. He then pays out this line and acts as immediate assistant to No.1 for the purpose of signalling and communication.

No.1 receives his instructions from the party leader as to the work involved and puts on his facepiece (by moving his helmet to the back of his head so that the chin-strap remains underneath his chin, adjusting the facepiece, and testing for gas tightness by squeezing the flexible connecting tube, then replacing his helmet on his head and adjusting the chin-strap.)

No.1 takes in with him a hand-lamp and such small items of equipment as may be necessary.

After the rescue has been completed and before the facepiece is returned to its haversack the eye pieces must be anti-dimmed. This should also be done periodically in order that the sets are always ready for immediate use. Normal precautions should also be observed regarding periodical cleansing and disinfection of facepieces.

PROTO REMOTE BREATHING APPARATUS

7. This is an apparatus widely used in the Forces, mines and various fire services. It is of an advanced nature, being completely self-contained with oxygen cylinders. The endurance limit is two hours, though, due to the weight of the apparatus, the wearer must be of a good physique to work comfortably for that period. Owing to the expense and the difficulty there would be in replenishing oxygen cylinders in times of disaster, it is not envisaged that the equipment would be in wide use with rescue parties. However, it is necessary that rescue personnel know something of this type of equipment.

ACCIDENTAL CASES

8. Some of the gases which may be encountered in effecting the rescue party are:-

- (a) Coal Gas
- (b) Ammonia Fumes
- (c) Sewer Gas
- (d) Carbon Monoxide

CONCLUSION

9. The object has been to teach the use of the R.B.A. and the accidental gases encountered in rescue work.

S.A. POLICE DEPARTMENT
EMERGENCY FIRE SERVICES
Police Barracks
THEBARTON

BLANKETING AND LASHING A STRETCHER

OBJECT

To teach the method of blanketing and lashing a casualty to a stretcher.

EQUIPMENT

Stretcher, Army Mark II.
2 x blankets (single size) or improvised blankets.
1 x 40' x $\frac{1}{2}$ " manilla lashing.

INTRODUCTION

One of the largest killers, besides injuries themselves, is SHOCK. This information can be gained from any medical man, who will agree the treatment for shock is warmth.

Before an injured person is placed on a stretcher it should be covered with a blanket lengthwise, so that the patient does not lie in direct contact with the canvas bed portion.

This adds to the patient's comfort and keeps him warm, thus reducing shock. It is more important to place blankets under him than over him.

With two layers of blankets underneath and one on top, a patient is better off than with one layer underneath and two on top.

GENERAL

Two blankets only are required to blanket a stretcher properly, as shown in the diagrams, A,B,C, and D.

(1) Lay one open blanket lengthwise across the stretcher, with one side close to the head end and one end of the blanket having a slightly longer overlap of the stretcher than the other end.
(See Diagram 'A')

(2) Fold the second blanket in three folds lengthwise and lay it on top of the first blanket along the stretcher, with its upper edge about 15 inches below the upper edge of the first blanket.

There will now be four thicknesses of blanket upon which the patient will lie.

Open out the two ends at the foot of the blanket for about two feet (2ft.) to form two flaps.
(See Diagram 'B')

(3) Roll up or pleat in concertina fashion the overhanging ends of the blanket and place them on the edges of the stretcher so that they will not drag on the ground when the stretcher is brought close to the patient.

(4) When the patient is laid upon the stretcher, wrap the two flaps of blanket around his feet and tuck ends between them.

Open out the rolled up folds of blanket and wrap, first the short and then the long end around the patient and tuck in well at one side.

The patient will now be warmly blanketed.
(See Diagram 'C')

/Cont. 2.

EFS/CD. No. 4/3
1965

A simple blanket lift can be used to transfer the patient from the stretcher to a bed by two persons. One gripping the shoulders and the other the feet.

IMPROVISED LASHING

In the improvised method with the 40 ft. lashing line, the only knot used is the clove hitch, which is as simple to tie in the darkness as in daylight, and which will never fail.

It is formed by making two loops in the rope, both anti-clockwise, the second loop, which tends to come in front, being placed behind the first.

It can also be formed by making a loop on the handle of the stretcher, so that the running end is imprisoned by the standing part, followed by another loop.

Form the first knot on a handle near the head of the patient, pass the rope down the side of the stretcher, taking a complete turn under the stretcher and back over the patient's chest, forming a half hitch.

At least three (3) turns must be used, two above the knees and one below.

The rope is then passed around the patient's feet, brought up on the opposite side of the stretcher and fastened with a clove hitch on the opposite handle near the head.

(See Diagram 'D')

Care should be taken to prevent the turns and the half hitches of the lashing from pressing on the patient's injuries.

DIAGRAMS

EFS/CD. No. 4/3

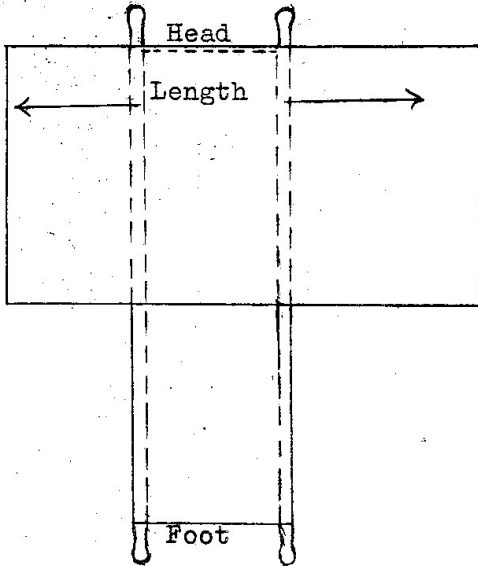

A

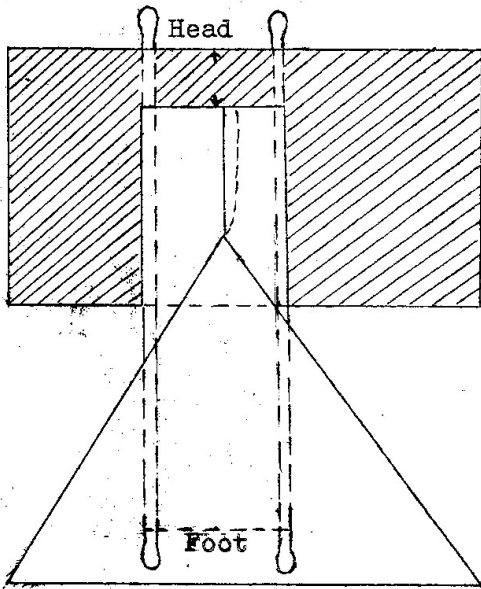

N.B. Shaded Portion denotes 1st blanket.

B

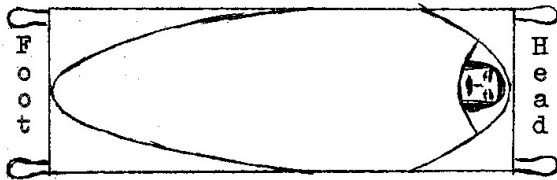

C

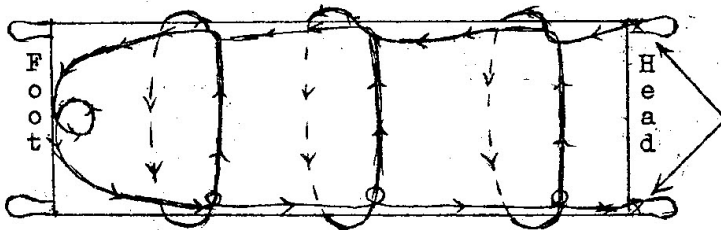

Clove Hitches on both handles

D

S.A. POLICE DEPARTMENT
EMERGENCY FIRE SERVICES
Police Barracks
TIEBARTON

E.F.S./CIVIL DEFENCE

RESCUE FROM HEIGHTS.

INTRODUCTION:

In certain instances when ladders cannot be used or are not available to effect a rescue, it may be necessary to use the two point or four point suspension method. Both methods can be used for lowering or raising. It may be necessary to use the well-hole of a damaged staircase or to enlarge an existing hole in a floor which has been caused by damage, or even in some cases to cut a hole in a floor large enough to take the stretcher. These methods can also be used in lowering from a window or other opening.

If it is necessary to make a new hole in a floor it should be cut near the walls, the centre of the floor being avoided where possible.

Floor boards will have to be taken out or sawn through and part of the joist removed, leaving a hole of the required size. The floor boards should be removed with a wrecking bar and the length of the hole must be parallel to the joists to avoid cutting more than one, as each one cut weakens the floor.

SUSPENSION METHODS OF LOWERING OR RAISING CASUALTIES BY ROPES:

TWO POINT METHOD -

In this method the hole need only be a little more than the width of the stretcher.

The casualty is secured to the stretcher by means of an improvised lashing. Head of casualty secured firmly by a triangular bandage.

- (a) One 40 ft. lashing should be fastened over the handle and through each 'D' at the head of the stretcher by means of a bowline for lowering.
- (b) One 40 ft. lashing should be fastened over the handle and through each 'D' at the feet to act as guide lines. Guide lines must keep the stretcher clear of the wall as it is being lowered.
- (c) Two men should be at the lower level to grasp the guide lines once dropped from the opening and to receive the stretcher as it is passed down to them.
- (d) Two men are required to lower stretcher; the guide lines are dropped through the opening and grasped by the two men at the lower level; the stretcher is then carefully passed through the opening, feet first and lowered slowly, the rope being paid out hand over hand.

The two point method has the advantage of requiring a much smaller hole through which to lower a casualty. There are, however, the usual limitations where tilting of a stretcher is concerned, e.g. the injuries may be of such a nature that the rescue personnel could clearly see some danger in adapting the two point method. In such a case the four point method should be employed.

FOUR POINT METHOD -

In this method a hole should be made in the floor large enough to take the stretcher in the horizontal position, i.e., much greater in size than that needed for the two point method. Four men will be required for heavy casualties but two men can do the job in the case of a light casualty.

- (a) With the casualty securely lashed to the stretcher, two 10 ft. lashings should then be fastened, one at each end of the stretcher, each end of the lashing being fastened through the "D" of the stretcher in the normal manner described in the two point method.
- (b) With one receiver manning each rope at the corners of the stretcher, it should be lowered by carefully paying out the ropes hand over hand so that stretcher is kept steady.

The head of the casualty can if desirable be kept higher than his feet, depending on the nature of his injuries.

Normally the stretcher should be kept in a horizontal position.

Two men should be on the lower floor to receive the stretcher as it is passed down to them.

-----000-----

S.A. POLICE DEPARTMENT
EMERGENCY FIRE SERVICES
Police Barracks
THEBARTON

EFS/CD.No.4/13.
1963.

E.F.S./CIVIL DEFENCE

CASUALTY HANDLING

Part 1.

OBJECT

To teach the following in Casualty Handling:-

- (a) Procedure involved with casualty handling.
- (b) Classification of casualties.
- (c) First Aid problems relevant to nuclear weapons.
- (d) Stretcher handling.
- (e) The use of improvised stretcher equipment.

GENERAL

Thorough knowledge of the procedures involved in the handling of casualties is essential for all civil defence workers. Correct casualty handling can save many lives and considerably shorten the recovery of many of the injured.

The techniques outlined in Part 1 and Part 2 cover every aspect of casualty handling. The application of a particular method to a problem is dependent on:-

- (a) The nature of the casualty's injuries - slight or serious, conscious or unconscious.
- (b) The position in which the casualty is found - ample space, narrow void, limited headroom.
- (c) Number of rescuers.

One important point that must always be remembered is that only when the casualty is in imminent danger by remaining where he is, does removal take priority over stoppage of bleeding.

CLASSIFICATION OF CASUALTIES

All casualties can be classified under three main headings:-

- (a) Walking wounded.
- (b) Slightly injured casualties.
- (c) Seriously injured casualties.

Walking Wounded should, after necessary first aid treatment, be directed or sent to the nearest Mobile First Aid Unit (M.F.A.U.), but occasions will arise when a decision as to whether they can safely sent on foot or should go in a vehicle, may be difficult. The following are examples of some types of walking wounded casualties who should NOT be allowed to walk.

- (a) If there is a marked degree of shock, which may be out of all proportion to the injury received.
- (b) If there is the slightest doubt as to whether there is an internal injury or not; cases of multiple small injuries, although apparently superficial, may have caused some internal injury.
- (c) Casualties who have bled from an artery, even in a small wound.
- (d) Casualties with head wounds, even though they may appear slight.

(e) All cases of poisoning by a nerve or lung irritant gas must on no account be allowed to walk but must be sent at once to a hospital as stretcher cases.

Slightly Injured Casualties are those whose injuries require that they must be evacuated for further treatment in cushion or base hospitals but the nature of the injuries does not necessitate the use of a stretcher and evacuation can be effected by sitting case car. A few examples of slightly injured casualties are:-

- (a) Cases of serious shock.
- (b) Casualties with an injury to a lower limb, unless it is only a very slight flesh wound.
- (c) Cases who appear to be suffering from gas poisoning or radiation sickness.

Seriously Injured Casualties are those will require hospital treatment. They must be allowed to walk or be sent to the M.F.A.U. but should be taken from the ambulance loading point by ambulance to hospital. It might be necessary, where conditions permit, to take those too seriously injured to endure the long journey to the M.F.A.U. where the medical officer would prepare them for their journey. A few examples of cases requiring hospital treatment are:-

- (a) All cases of internal haemorrhage; open wounds of the chest (pneumothorax); shattered limbs, grossly lacerated and crushed limbs; stomach wounds; open complicated fractures; fractures of the skull, spine, pelvis and thigh; injuries involving the eye; injuries involving the lower jaw and control of the tongue.
- (b) Cases of severe external haemorrhage and of multiple or extensive burns.
- (c) Cases in which further shock is likely to supervene, as in persons trapped for long periods under debris, or exposed to cold and wet; in fact, all but those with trivial injuries or who are merely shaken, frightened or faint. It must not be forgotten that very small external wounds may be associated with damage beneath the surface.
- (d) All diabetic patients who may be injured or who are suddenly taken ill.

FIRST AID PROBLEMS RELEVANT TO NUCLEAR WEAPONS

It is not the purpose of this Circular to teach first aid but some factors relevant to nuclear weapons are mentioned in this section.

(a) Temporary Blindness Caused by Atomic Flash. Casualty section personnel must remember that persons standing in the open and facing the flash of the nuclear explosion may be temporarily blinded. This condition resolves itself without treatment in a matter of hours. The person requires reassurance that this loss is only temporary.

(b) Flash Burns from Nuclear Weapons. Flash burns are produced by the intense heat released at the time of the explosion. The rays producing the flash burns have a low degree of penetration but have a severe action on the surface of any object struck by them. Solid objects in the path of these rays have a protective effect. Depending on the distance from Ground Zero ("GZ"), normal clothing will afford some protection and light coloured clothing even more. Multiple layers of clothing are more protective than single layers. Flash burns have another interesting characteristic in that they only affect the surface of the body directly exposed to the ray.

The burns are "superficial" rather than "deep" and vary from something comparable to severe sunburn to severe blistering with loss of the surface cuticle. They are extremely painful. The first aid treatment for flash burns is the same for ordinary burns.

(c) Radiation Sickness. Radiation sickness is not a first aid problem in the immediate post disaster area. However, casualty section members need to understand the symptoms which may develop and the principles recommended for treatment.

Victims of radiation, if otherwise not injured, may be capable of walking around immediately after the incident without apparent ill effects. In an hour or two or even later, nausea and vomiting may develop, but it is important to remember that fear and anxiety may also produce these same effects.

Within days to weeks some radiation casualties may exhibit loss of appetite, tiredness and diarrhoea. Resistance is considerably lowered and various infections may develop after several days, or even weeks.

Spots ranging in colour from red to purple (purpuric spots) and varying in size may appear on the skin and mucous membranes. Loss of hair occurs in certain cases after a week to several weeks but the hair will grow again.

Radiation casualties should have rest and transportation to available medical facilities. They should be stretcher cases and every effort should be made to keep them as cheerful as possible. Even insignificant wounds should be carefully protected as the patient's resistance to infection will be very much lowered.

(d) Emotional Disturbances. Individual emotional reactions will vary considerably after a nuclear attack or any major disaster. Broadly, the reactions will fall into three overlapping phases. First, a period of impact with the initial stresses followed by a period of recoil in which the individual becomes aware of what has happened, and finally, the period of adjustment, the post shock period.

During and immediately following a disaster some people will show periods of compulsive behaviour based on a desire to escape and rescue their families and belongings. They are liable to be confused and unable to concentrate. Most survivors are dependant upon other people and need, above all, guidance and leadership. This leadership will probably come initially from that 10-15% of the population who have the ability to remain calm in an emergency particularly if they have been trained for the job. About three-fourths of the survivors will react normally to the period of impact, being stunned, bewildered and easily led.

The remaining 10-15% will show more severe reactions, such as hysterical behaviour, confusion and paralysing anxiety. Those showing gross behaviour disturbances must be dealt with straight away to prevent the spreading of panic.

Some people will, as the result of this emotional disturbance, develop physical symptoms, such as nausea, vomiting, loss of appetite, sweating, trembling and palpitation of the heart. These are quite normal symptoms though if they have not gone after several hours, medical attention should be sought.

(e) First Aid for the Emotionally Disturbed. Before anyone is capable of rendering efficient psychological first aid in a post disaster situation, it is essential that they be calm themselves. Some symbol of authority, such as a uniform or an armband, is necessary. When addressing a group speak loudly and distinctly, but be brief and to the point. Speak, if possible, from a vantage point.

Give such directions that will lead to activity, such as locking after each other's needs or acting as stretcher bearers. Singing is a good method of distraction from the serious side. Never move in an excited or rapid manner, encourage others to do likewise. Grossly disturbed individuals should be treated promptly. This can be done by a sympathetic and reassuring approach, if possible, use their name when speaking with them. Speak quietly but firmly and be brief. If the individual does not settle down, remove them from the group. Remember, panic can quickly spread, especially from an emotionally disturbed person.

After the disaster, during the period of adjustment, disorders lose their group aspect and become predominantly individual. They consist of night-mares and insomnia, startle reaction, anxiety and fear, abnormal and emotional thinking. Some bodily symptoms will appear and initial symptoms may fail to improve.

Psychological first aid is designed to prevent emotional reactions from becoming more severe or permanent, and by reassurance, control and direction to prevent the spreading of panic, rumours, etc., and to divert the individuals concerned into useful activity thereby adding to morale and the civil defence effort. The normal routine of life should be re-established as soon as possible, that is meals, meal hours, hours of work, shelter, etc.

HANDLING A STRETCHER IN DIFFICULT SITUATIONS

(a) A stretcher should, whenever possible, be carried in the horizontal position. There may be times when this is impossible as the casualty may have to be carried over debris and the bearers will have to climb up and down piles of rubble, etc. In such cases four or six bearers are an advantage.

If four bearers are available, one should be at the front end, one at the rear end, and one at each side of the stretcher. When they have to climb over a large heap of debris, the bearers at the sides turn inwards towards one another and take the full weight of the front end of the stretcher, while the front bearer climbs up on the debris; the front end of the stretcher is then lifted for him to grasp. The stretcher is then advanced and the bearers at the sides take the weight of the rear end of the stretcher while the rear bearer climbs on to the debris and grasps the rear end. A similar procedure is adopted when climbing down.

If only two bearers are available, it may be necessary to lay the stretcher down when they reach an obstruction so that they can ascertain the best method of getting over it. The bearer at the front end climbs on the debris, while the bearer at the rear end passes the front end of the stretcher up to him to grasp. The rear end bearer then resumes his position and lifts the stretcher to a horizontal position and the bearers cross the obstacle.

Care must be taken to see that the stretcher, if laid down, is resting on the "D's" with the bed of the stretcher clear of obstruction so that debris will not move under the weight of a human being and pieces of debris will not injure his body.

(b) Using a Stretcher in a Confined Space. In confined spaces, if there is sufficient height and the casualty has been secured to the stretcher, it may be stood on end, and by grasping the sides can be moved round sharp corners.

Where the height is insufficient to permit this method being used, as in the case of shelters, a compromise between horizontal and vertical positions is necessary. The casualty should be carried feet first as far as the middle of the right-angled bend, when the front end of the stretcher is placed on the ground and the rear end lifted as high as the roof will permit. The stretcher can then be worked round the bend, one bearer easing the front end and the other the rear end.

It should not be turned on its side or height will be lost and difficulties increased. At the same time there will be a risk of the casualty banging against the inside of the bend.

(c) Passing Over a Gap. When taking a casualty out of a damaged building it is often necessary to cross a gap in the floor. A ladder may be used as a bridge, providing that the precautions are followed.

Alternatively, two or more joists may be laid across the hole. They should be twice as long as the hole so that they rest on the sound joists of the damaged floor.

It is wise to use six bearers as a safety precaution when crossing a pile of debris which contains gaps. Two bearers go across the gap while the remaining bearers turn inwards and, lifting the stretcher, pass the front handles to them across the gap. The two rear bearers support the stretcher as it goes over and then relieve the front bearers, who cross the gap and take up their position ready to take over the rear end of the stretcher. The remaining bearers then cross the gap and take up their positions at the sides of the stretcher.

THE USE OF IMPROVISED STRETCHERS

When there is a shortage of stretchers it is better to improvise rather than manhandle the casualty unnecessarily. Some examples of improvisation are:-

(a) Doors used as stretchers. The door is placed with a brick at each corner and the casualty blanketed in the normal way. The usual lashing method is used except that instead of fastening the ends by clove hitches to the strings, bowlines are tied and looped over the corners.

(b) Ladders used as stretchers. A half of a short extension ladder, such as carried by the rescue party will make an ideal improvised stretcher. Again, bricks are placed under each corner. Some pieces of board usually 6' x 1" are placed in the the centre. The casualty is then blanketed in the normal manner. The lashing is altered slightly this time. It is begun with a round turn and two half hitches in the middle of a rung at the foot of the stretcher. Three hitches are then taken about the ladder and the casualty at the shins, the wrists and the chest; the centre line of the hitches will be along the top of the casualty so that the end will come across the injured person's shoulder and will be fastened to the centre of the rung next above the shoulders by another round turn and two half hitches. No tightening hitches are required.

(c) Mattresses can be used as emergency stretchers, especially if casualties are being removed from hospitals, etc.

(d) There are many other methods, including the use of chairs, overcoats with sticks, blankets with sticks, galvanised iron sheets and bed frames. The list could go on indefinitely but these will give some idea of the degree of improvisation possible in the event of a nuclear disaster.

CONCLUSION

Successful casualty handling has been described as the most important aim of civil defence. There is no doubt that efficient casualty handling in its many applications will do more to relieve suffering and expedite the recovery of stricken areas than any other aspect of civil defence. Part 1 of this Circular has described the procedures involved in casualty handling, the classification of casualties, first aid problems relevant to nuclear weapons and the use of improvised stretchers and stretcher handling. For Blanketing and Lashing a Stretcher, see Circular EFS/CD.No.4/3.

(Ref. C.D. Rescue Manual, C.S.2.)

CASUALTY HANDLINGPart 2.OBJECT

To teach the following in Casualty Handling:-

- (a) Emergency Methods for One Rescuer:
 - (i) Pick-a-back.
 - (ii) Human crutch.
 - (iii) Fireman's lift.
 - (iv) Fireman's crawl.
 - (v) Removal downstairs.
- (b) Emergency Methods for More than One Rescuer:
 - (i) Two-man human crutch.
 - (ii) Fore and Aft method.
 - (iii) Two handed seat.
 - (iv) Three handed seat.
 - (v) Four handed seat.
- (c) Removal of Casualties on to Stretchers:
 - (i) Webbing bands.
 - (ii) Blanket lift.
 - (iii) Clothing lift.
- (d) Handling of Bodies.
- (e) Casualty Labelling.

GENERAL

When casualties are in danger of receiving further injuries, by fire, coal gas, flooding or from dangerous structures such as leaning walls, etc., it is necessary to remove the cause of danger from the casualty or the casualty from the danger. If it is vital to remove the casualty to safety, he must be moved, regardless of his injuries. Only when the casualty is in imminent danger of death by remaining where he is does removal take priority over the stoppage of bleeding. There are several methods by which he can be moved, among them being by the use of webbing bands, the pick-a-back, human crutch, fireman's lift, fireman's crawl, fore and aft method, two handed and four handed seats.

VARIOUS TYPES OF HAND CARRIAGE - Methods suitable for one rescuer.

- (i) Pick-a-Back. Carry the casualty in the ordinary pick-a-back position. This is the best way if he is conscious and able to hold on.
- (ii) Human Crutch. Where the casualty can help himself, the rescuer stands at his injured side and places the casualty's arm around his shoulder, grasping the wrist with his hand. At the same time he passes his other hand around the casualty's waist, gripping his clothing at the hip and thus assists him by acting as a crutch. Each person should step off the outside foot - the rescuer using his nearest to the casualty as a prop - as in a three-legged race.
- (iii) Fireman's Lift. (Given as the standard S.A. Fire Brigade-S.A. Emergency Fire Services drill. Taken from E.F.S. Training Circular No. 12/4/2.)

This is one way of carrying a helpless or unconscious person and allows the rescuer a free hand. It is easier for the rescuer than the pick-a-back method, but not so comfortable for the casualty.

This method should be used when it is known that gases heavier than air are present (e.g. petrol vapour, sulphuretted hydrogen, Sulphur dioxide, nitrous fumes, etc.)

Drill: Locate casualty. If in smoke, do not lose contact.

1st Movement: Place casualty in prone position (lying on face), straighten casualty - starting from the head, turn head to one side and clear mouth, place arms to sides, legs together. This movement is carried out by the rescuer walking astride the casualty. Step to the right of the casualty and retrace steps (backwards), maintaining left hand on casualty, returning to head.

2nd Movement: Raise casualty on to his knees by gripping casualty firmly under armpits.

3rd Movement: Lift casualty on to his own feet by grasping strongly around chest, hold him firmly under armpits with your right arm, take firm grip of casualty's right wrist with your left hand, place your right knee between casualty's legs to help take the weight and to prevent the casualty from slipping to the floor.

4th Movement: Squat quickly, at the same time slipping right arm between the casualty's legs and pulling him across your own shoulders, using the grip on his right wrist to assist in drawing him across.

Correct the balance of weight before rising from the low squat position.

To carry the casualty down a ladder, it is most important that the casualty be perfectly balanced across the shoulders so that the rescuer's hands are free to grasp the rungs of the ladder. (See EFS/CD.No.4/7.)

(iv) Fireman's Crawl. If a rescuer finds an unconscious casualty, or one who is unable to help himself, or who is too heavy for one of the above three methods to be applied, the Fireman's Crawl can be used as follows.

Turn the casualty on his back and tie his wrists together (use handkerchief, sashcord lashing, etc.) Kneel astride him facing his head and place your head through the loop thus formed by his arms. By crawling on your hands and knees you can then drag him with you, even though he may be heavier than you are.

(v) Removal Downstairs. To move the casualty downstairs, lay him on his back, head towards the stairs and secure his wrists together. Place your hands under his armpits and grasp his wrists. Moving backwards, ease him gently downstairs.

VARIOUS TYPES OF HAND CARRIAGE (Cont.) - Methods suitable for more than one rescuer.

(i) The Fore and Aft Method. In this method the wrists are tied and the trunk lifted in the same way as the removal downstairs method by the rescuer. The other rescuer takes one leg under each arm and they carry him feet first. If one leg is broken, both legs should be tied together or put in splints and both legs carried under one arm.

(ii) Two Handed Seat. Two rescuers face one another on either side of the casualty and stoop. Each rescuer passes his arm nearest the casualty's head under his back just below the shoulders and, if possible, grips his clothing. They raise the casualty's back and slip their other arms under the middle of his thighs, clasping their hands with a hook grip. The rescuers rise together and step off with short paces.

(iii) Four Handed Seat. (See attached diagram). The rescuers face each other and each grasp their own left wrist with their right hand. Their hands are then put together, the free left hand grasping the right wrist of the man opposite. The casualty puts one arm or both arms around the necks of the rescuers.

The three handed seat is a variation of this method.

REMOVAL OF CASUALTIES ON TO STRETCHERS

(i) Webbing Bands. Sets of webbing bands are carried by Rescue Parties and are used: (1) For lifting a casualty from the ground on to a stretcher; and (2) For lifting and carrying a casualty from a place where it is impossible to take a stretcher.

Each set consists of four bands made of stout canvas webbing $4\frac{1}{2}$ inches wide and of two different lengths, two being 2 feet long and two 3 feet long. The shorter bands are intended to go under the head or neck and the feet, and the longer ones under the chest and hips (or small of the back). At the ends of each band is a handle, a long and short, made of $\frac{1}{4}$ inch drawn steel wire welded at the joint, the long handle being 12 inches long and the short 4 inches.

The long handles are used for pushing under the body of a casualty lying on the ground, after which the webbing band is pulled through so that there will be a handle at each side. When pushing a band under a casualty the long handle is grasped by a rescuer with his right hand at the point where the handle joins the canvas, he then slightly raises the casualty from the ground with his left hand and pushes the handle under his body; the rescuer on the other side then raises the casualty slightly with his left hand and pulls the handle and band through with his right hand. It is only necessary to raise the casualty a $\frac{1}{2}$ inch from the ground. When a casualty is lying close to a wall or other obstruction, it is not possible to pull the long handle through, so the short handle is bent over the long handle and pushed through by it; the short handle is then pulled through and the long handle withdrawn at the same time.

Several methods of carrying casualties by webbing bands have been adopted to meet different situations. Training and practice in the carrying of casualties by these bands is essential. It must be remembered that these webbing bands are not to be regarded as a substitute for a stretcher, but only as a means of taking a casualty to a stretcher from a place where it is impossible to use one.

(ii) Blanket Lift. When a casualty is being removed from a void, space may not permit the use of a standard stretcher. In these cases a blanket lift may be used which will be more comfortable for the casualty and easier for the party to handle. It is made by doubling the blanket length-wise, and rolling the edges in fairly tightly to the side of the casualty, thus forming a handhold for the bearers.

(iii) Clothing Lift. In this method of loading a stretcher, five personnel are required. Two on each side of the casualty and one at the head. The casualty is eased gently on to his side and two rescuers place their arms under the shoulders and lower buttocks and grasp the clothing on the opposite side of the casualty to them. The two rescuers on the other side then do likewise and the fifth man (the man in charge) supports the head. The casualty can then be transported (using side steps) and loaded on a stretcher.

HANDLING OF BODIES

Whenever possible, civil defence personnel handling remains, should use the rubber gloves issued for the purpose. Where necessary, they should tie a pad or handkerchief dipped in some deodorising fluid over the nose and mouth. Where such fluid is not available, wearing of respirators will help overcome nausea caused by foul smells.

Where bodies are recovered they should be deposited in the nearest convenient building and some suitable covering placed over them, such as tarpaulins, pending removal to temporary mortuary. They should not be left in roads or other open spaces. The public and all persons not directly concerned should be kept away whilst bodies are being recovered.

The dead should be treated with due respect, but priority must always be given to the living.

Parts of bodies should be placed in metal bins, labelled and sent to the mortuary.

On no account should anything be removed from the dead or casualties, except that which may be necessary to establish their identity.

Any article of value, however small, found or removed from damaged premises must be handed in. Greatest possible care must be exercised in this matter. To safeguard himself, the finder should immediately declare objects found, handing them in at the first opportunity and obtaining a receipt for same.

In the absence of a doctor the Party Leader should take the responsibility of diagnosing death in clear cases, but where there exists any doubt as to whether life is extinct the advice of a doctor should be obtained on the spot.

If no doctor is available, to avoid delay the casualty should be sent direct to a hospital and not to a first aid post.

CASUALTY LABELLING.

Bodies must be labelled when they are recovered. The standard casualty label will be used and the front side completed. The following symbols are to be entered on the reverse side of the label, are also applicable.

(i) If a body is contaminated or suspected of having been contaminated by persistent gas, the label should be clearly marked with a "C".

(ii) For those suspected of having died from the effects of poisoning by nerve gas or non-persistent gases, the label should be clearly marked "XX".

(iii) For those suspected of having died from radioactive effects, the label should be marked "R".

CONCLUSION.

The purpose of this Circular has been to outline the various methods of Casualty Handling for use by one or more rescuers.

Remember, all persons injured are to be called "Casualties" until seen by a doctor, then they are called "Patients".

In conclusion, it must be stressed again that only when the casualty is in imminent danger of death by remaining where he is does removal take priority over stoppage of bleeding.

(Ref. C.D. Rescue Manual, C.S.3.)

S.A. POLICE DEPARTMENT
EMERGENCY FIRE SERVICES
Police Barracks
THEBARTON

RESCUE FROM BASEMENTS

1. In certain areas, domestic property and nearly all large buildings have basements or cellars sunk partly or entirely below ground level.
2. Unlike upper storeys, where the problems are generally similar whatever the type of building, rescue from basements presents a variety of problems depending upon the type of building involved.
3. It is of the utmost importance that rescue workers should be familiar with the various forms of construction used in basements, for many basements may be specially strengthened for use as a place of refuge.
4. Rescue parties are frequently called upon to extricate trapped persons from basements of demolished buildings, either when the basement ceiling has collapsed or when (probably as a result of strengthening) it has stood up to the debris load.
5. The first task is to try and discover the layout and extent of the basement, the location of the entrance and emergency exit, and whether or not there are basements in the adjoining buildings. Steps should also be taken, if possible to determine from an examination of the outside whether or not the ceiling has collapsed, and, if so, in what way.

BASEMENTS MAY BE DIVIDED INTO FOUR TYPES

6.
 - (a) Domestic, i.e., residential dwellings.
 - (b) Business, i.e., warehouses and department stores.
 - (c) Large Office Blocks, i.e., accommodation of heating plant, air plant and staff.
 - (d) Public Buildings and Theatres.
7. Following a rapid investigation of these matters, entrance to a basement should be effected in one or more of the following ways:-
 - (a) In domestic property the normal way of access to a basement is by a small staircase situated below the main staircase of the house. An important point to note about domestic basements is that most of them are provided with some form of window coal chute.
 - (b) In large buildings built alongside pavements, basements usually extend for a distance of two or three yards under the adjoining pavement, and in this portion are usually found the coal chutes, pavement lights and so on, which afford some means of entry to basements.
 - (c) By breaking through the wall from an adjoining basement which has not been so severely damaged. To increase the probability of reaching quickly a void which may have been formed by the collapse of the basement ceiling, it is better to break through the void at a point near the centre of the basement. Consideration must of course be paid to the construction and thickness of the wall.
 - (d) A manhole or emergency exit leading from the basement outside may be cleared of debris and an entrance effected in this way.
 - (e) Where the ground floor has not collapsed a small area may be cleared either by tunnelling to the spot or by removing the debris from the side and cutting a hole in the floor to give access into the basement.

RESCUE FROM BASEMENTS

CONTINUED

- (f) Where the basement ceiling has completely collapsed, a tunnel or a hole may be driven from the edge of the debris downwards to the floor of the basement. From this point exploration of the basement can be continued by working round the walls to all available voids.
- (g) An improvised shaft or ramp may be sunk in the ground immediately outside the building and, if possible, alongside the outer face of the basement wall, through which a hole can be broken.

8. Care must be taken not to cut too large a hole, as this may cause the collapse of the brick arch.

It is equally necessary to avoid cutting through service pipes and cables.

If the basement ceiling has collapsed, a solid mass of debris may be revealed inside when a hole is cut through the outer wall. In this case a debris tunnel must be cut through this debris.

Once a void has been reached, it should at once be made safe with props and other timbers against the possibility of further collapse.

CIVIL DEFENCE ORGANISATIONSOUTH AUSTRALIACIVIL DEFENCE - INDIVIDUAL DOSIMETER.1. PURPOSE.

The individual Dosimeter has a primary and a secondary use, as follows:-

- (a) Primary Use: To measure amount of radiation which its user absorbs whilst operating in a contaminated area. (For those who happen to be within range at time of explosion, it will also be affected by initial gamma dose.)
- (b) Secondary Use: To act as a simple form of radiac survey meter i.e., to enable user to make rough estimates of the rate at which radiation is being received. By this means those who are not provided with radiac survey meters can make a rough estimate of safe working time in an area, and if dose rate is negligible can reassure the public.

2. SERVICE TYPES

Produced in three ranges as follows, all being outwardly similar in appearance:-

- (a) Reading up to 50r: For use in target areas likely to be subjected to an attack capable of producing heavy contamination or where prolonged exposure is required.
- (b) Reading up to 5r: For use in areas where high levels of contamination are unlikely, or short periods of exposure only are necessary. (The 0 to 50r type is comparatively insensitive in the lower ranges and is of little use in recording small doses acquired by those moving in and out of highly contaminated areas or operating for longer periods in less contaminated areas.)
- (c) Reading up to 150r: For use in special circumstances to record the initial gamma radiation, but this is not a normal function of the individual dosimeter as used by Civil Defence personnel.

3. TRAINING TYPE

Similar in appearance to service types, but more sensitive so that it will react to weak radioactive sources authorised for training. Scale reads 0 to 0.5r.

4. PRIMARY USE - HOW TO TAKE A READING

With both service and training types, apply clip end of dosimeter to eye, when scale will be visible against light. Thin quartz fibre line will be seen crossing scale; point where it crosses indicates dose received. (Each member of class to be practised in taking reading with training type dosimeter on which a dose has already been received.)

5. SECONDARY USE - AS IMPROVISED RADIAC SURVEY METER

First read dosimeter and note reading. After period of measured time, say 10, 12 or 15 minutes (a time which will conveniently divide into 60) again take reading. The difference between the two readings, when multiplied by 60 and divided by lapse of time in minutes, gives approximate dose rate in roentgens per hour. For example, if dosimeter reads zero to start with, and again after 15 minutes registers 0.25r, average dose rate is 0.25×60 divided by 15 = 1r per hour. (Instructor gives example and class practice making calculations.)

6. MAINTENANCE OF INDIVIDUAL DOSIMETER.

Checking of calibration: To make a check reading of training type individual dosimeter, place one Type A source three inches from a point on the dosimeter which is two inches from the charging end as described below. If left for one hour in this position, dosimeter reading should be about .07r. For more accurate check, dosimeter should be exposed in this position for five hours, when reading at about .36r, or about two thirds full scale deflection, will be obtained. A suitable method of carrying out this operation with a number of dosimeters is as follows:

- (a) From the standard container, remove the Type A source with its supporting rod.
- (b) Set up the dosimeters on end, with the eyepieces upwards round the inside rim of the standard container of the Type A source. In this position, the dosimeters form a circle having a radius of three inches from the centre.
- (c) Fit a rubber band, or clip, round the supporting rod of the Type A source, two inches from the tip of the source.
- (d) Place the Type A source and supporting rod **UPSIDE DOWN** in its normal hole and **NOTE THE TIME**. The rubber band or clip, will ensure that the source protrudes two inches from the top of the hole, which is the right height to radiate direct into the ionisation chambers of the surrounding dosimeters.
- (e) At the end of the hour, or five hour period, withdraw Type A source and supporting rod and correctly replace in container. The dosimeters can then be removed and read at leisure.

Adjustment: Local adjustment is limited to recharging the dosimeter using the charging unit.

Servicing: Broken spring clip to be replaced by local purchase.

Ref. C.D. Manual RAD.1.

POCKET QUARTZ FIBRE ELECTROMETER (FOUNTAIN PEN DOSIMETER)

A convenient and accurate personal monitoring device in the form of a small electrometer, comprising a small condenser ionisation chamber (a) with an optical indicator, (b). Can be carried on the person, worn like a fountain pen.

Eye Piece

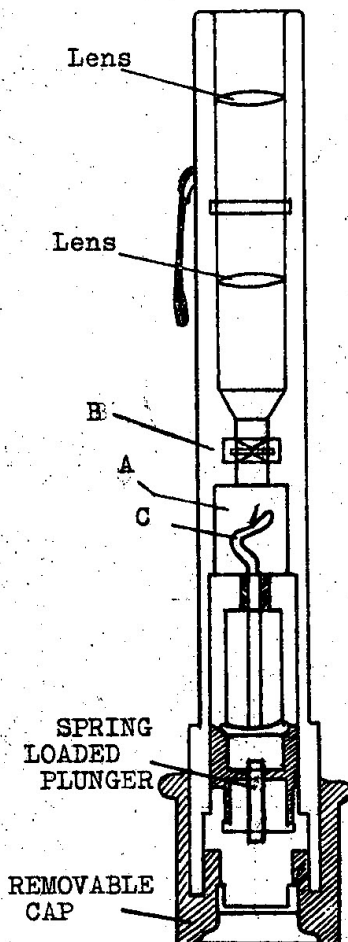

The inner electrode (c) of the condenser chamber is attached to a quartz fibre movement whose position may be viewed through the microscope system located at one end of the assembly. At the opposite end is a threaded cap, the removal of which exposes a spring loaded plunger connected to the inner electrode when it is required to charge the device.

Initially the chamber is charged to a potential of 150 volts by a special charging unit. The charge deflects the quartz fibre to the zero position when viewed through the microscope.

When the chamber is subjected to radiation the ionisation of the dielectric in the chamber caused the applied charge to leak away and a consequent deflection reduction of the quartz fibre, this being read off as an indication of dosage of Roentgens received.

The range of the typical instrument would be in twenty milli-roentgens from Zero to $\frac{1}{2}$ roentgens. Instruments are available for much higher readings in the range of 500 roentgens at which dosage the reader would be most unlikely to require the use of the instrument again.

CIVIL DEFENCE ORGANISATIONSOUTH AUSTRALIACIVIL DEFENCE - THE CONTAMINATION METER1. PURPOSE:

To detect the presence of radioactive contamination on the skin, clothing or equipment of those who have been in heavily contaminated areas.

The chief danger of such contamination is the beta hazard if it is allowed to remain on the skin or the clothing for a prolonged time, with of course, the risk that some of it may later accidentally be taken into the body through the mouth, nose or wounds and abrasions.

It is difficult to measure beta intensity directly, but, since the beta rays from the explosion products are always accompanied by gamma rays, in a known proportion, the measurement of the latter is an indirect measurement of the former.

Since the contamination meter is extremely sensitive to, and will measure, very small gamma ray doses, it cannot be used in a contaminated area unless it is completely shielded from the general 'background' radiation, as it is called, since this will mask the small effect from the contamination on any one individual being checked. Such shielding is not easy to achieve, and the instrument must therefore, in general, be used away from contaminated areas. It is intended that contamination meters will be installed in such places as hospitals and depots, etc.

2. INTRODUCTION:

The Anton V-700 is a portable, battery powered, transistorized survey meter with a regulated power supply, using an Anton type stainless steel, halogen quenched Geiger-Mueller tube as the detector. The geiger tube is mounted in a probe connected to three feet of cable. The instrument and its accessories include a circuit chassis, a probe, a headphone, a carrying strap and a radioactive source mounted under the name plate.

3. THE PROBE:

The probe consists of a nickel plated brass housing with a beta window provided with detents, which can lock it in either the open or closed position. The probe contains the geiger tube which is sensitive to moderate and high energy beta radiation and to gamma radiation down to low energies. The geiger tube is mounted through a rubber gasket and is held in place by a coil spring.

4. THE CIRCUIT CHASSIS AND CASE:

The circuit chassis and case consists of the 5 each 1½ volt type D supply batteries, a transistorized pulse shaping network a detecting (Metering) circuit, a regulated transistorized high voltage power supply, an audio pulse amplifier and a radioactive D+E source. The system is shock proof and water proof, and is secured with rapid takedown clamps in order to make access very simple. The battery bracket faces out for rapid removal and replacement of batteries, and protection of the circuitry from battery 'leakage'.

5. THE HEAD SET:

The head set is a single piece magnetic phone with a connector mated to the watertight jack, mounted on the lid. The watertight jack is kept covered by a plastic dust cover.

6. THE CARRYING STRAP:

The carrying strap is made of plastic. It is provided with adjustment clips. The strap is adjustable from 30 inches to 60 inches in length.

7. INSTALLATION:Installing the Batteries:

The instruments are shipped with the batteries packed separately. To put the instrument into operation:

- (1) Open the case by releasing the clamps at both ends, and remove the lid assembly.
- (2) Remove the batteries from their package, taking care not to drop them.
- (3) Loosen knurled battery clamp nuts and remove clamps.
- (4) Place the 'D' cell batteries, negative end first, against the 'finger' springs and slide the positive terminals down in their respective grooves. Be sure all spring contacts are positively pressing against each battery. This may be adjusted with long nosed pliers if necessary.
- (5) Replace clamp - tighten the knurled nut.
- (6) Replace lid assembly on case.

8. OPERATION:(a) Operating the unit the first time:

With probe in the handle clip, switch the instrument to the times ten (X10) scale with the beta window closed. Wait 30 seconds. The meter should read substantially zero. Present the open window of the probe to the centre of the nameplate under which is a radioactive sample, make sure the geiger tube is directly over the dimple on the nameplate. The indicator should fall between 1.5 milliroentgens per hour (mr/hr) and 2.5 mr/hr, averaging about 2.0 mr/hr.

(b) "On-Off" and Range Switch:

The range switch controls an 'OFF' position and three ranges labelled, 'X100', 'X10', and 'X1'. These are respectively 100 times, 10 times and 1 times the scale reading in mr/hr and counts per minute. The printed meter scale goes to 0.5mr/hr and 300 counts per minute respectively.

(c) Using the Head Set:

To use a head set, the phone connector is attached to the terminal located immediately to the left of the post of the handle. In using the head set, the counting rate is indicated by distinct clicks, the frequency of which is equal to the count rate.

(d) Normal Back-ground:

Since normal background of radioactivity will be in the order of 0.01 to 0.02 mr/hr, as recorded on this type of instrument, little activity will normally be seen or heard. Under background conditions only, about 20 per minute of these 'clicks' will occur. They are randomly spaced so that one may wait for several seconds before any 'click' is heard: then there may be two or three.

(e) Using the Carrying Strap:

The instrument may be carried in the hand or by a strap over the shoulder. The strap anchors are arranged in such a way that the meter is visible when carried over either the left or right shoulder. Quick 'connect and disconnect' fasteners are provided.

9. PREVENTIVE MAINTENANCE:(a) Battery Life:

Caution:- Make certain the Instrument is Turned OFF whenever NOT in use. ('OFF' position places the range switch perpendicular to the handle axis.)

The life of the batteries is at least 100 hours under continuous use; for intermittent use the life may be extended. The indications that the instrument is ON are:-

- (i) the position of the range switch,
- (ii) clicks in the head phone.

(b) Storage:

The instruments are shipped in a packing container and should be left this way until ready to be put into operation. This prevents the accumulation of dirt, moisture and radioactive contamination, which would interfere with proper operation of the instrument. For storage purposes, it is best, wherever possible, to keep the instrument in a moderately cool area, as this will provide greater shelf life for the batteries. At all times, one should attempt to prevent contamination of the instrument and particularly the probe. The instruments should not be stored with the batteries installed.

(c) Decontamination:

Because this equipment may be used in areas where radioactive contamination is possible, it is recommended that the instrument, probe and accessories be cleaned (after exposure to such condition) in an accepted manner to avoid both spurious counting or residual radiation hazards.

The probe housing has been specifically designed to permit decontamination. To clean its parts, unscrew the cap end; slide the beta shield sleeve off the housing. All the component parts of the probe may now be cleaned.

(d) Battery Inspection:

Even under continuous use with leak-proof cells, it is advisable to check the batteries for leakage at least once per month.

10. OPERATOR'S MAINTENANCE:-

(a) Replacing the Batteries:

Whenever the instrument fails to respond to the operational check source, check the batteries. To replace the 'D' cells, see paragraph 7. If a voltmeter is available, one can check the 'D' cells. Cells showing signs of corrosion or providing less than 1.5 volts should be replaced, at this time.

(b) Replacing the Geiger Tube:

The chief maintenance required by this instrument is replacing the batteries. The Geiger tube is halogen quenched so that its operating life is unaffected by use and therefore rarely requires replacement. However, if fresh batteries are installed and the instrument still does not work correctly, it is preferable to check it with a new Geiger tube before making any further attempts at circuit checking.

(Caution:- In Removing or Replacing Geiger Tube Do Not Grasp Tube at Thin Section.)

-----oOo-----

CIVIL DEFENCE ORGANISATION
SOUTH AUSTRALIA

CIVIL DEFENCE - CHARGING UNIT.

1. To maintain their efficiency, dosimeters have to be reset before and after use by means of a specially designed, battery charging unit, which imparts an electrical charge to dosimeter and enables quartz fibre line to be set again at zero. This is necessary from time to time whether or not the dosimeter has been exposed to radioactivity, since there is a slight natural discharge from the instrument.

2. GENERAL DESCRIPTION

The Dosimeter Charger CD V-750 is a self contained battery operated instrument. This instrument will charge to zero, any self-reading dosimeter which has a standard military or O.C.D. charging end. The CD V-750 charging unit is specifically designed for use with Military, O.C.D. and Commercial Dosimeters.

The charger is contained in a two-part metal case, 4 by 4 by 2 inches, held together with a single captive screw. The charging contact is located in the upper left-hand corner and the voltage control knob in the upper right-hand corner. The charging contact has a screw-on cover which is permanently attached to the case.

3. THEORY OF OPERATION

The circuit is powered by a 1.5 volt battery. Pressure applied to the charging contact closes the switch and the bulb lights. Also the transistor sets up an oscillating signal which is amplified by the transformer and rectified by the diode thus a potential of 220 volts maximum is available at the charging pin. The dosimeter to be charged must be pressed down so that it closes the circuit between the charging pin and ground. Resistor varies the potential of the charging pin.

4. INSTALLATION

Remove charger and battery from package. Loosen the captive screw on the bottom of the charger and remove the cover. Insert the battery, carefully observing the polarity markings. Tighten the bulb in its socket. Replace the cover oriented so that the rubber pad is over the battery and tighten the captive screw. Remove the cap from the charging contact, and the charger is ready for operation.

5. OPERATION

To charge (Zero) Dosimeter.

1. Place dosimeter on charging contact and PRESS DOWN FIRMLY.
2. Rotate voltage control until hairline image on the dosimeter scale is at zero.
3. Remove dosimeter and check reading using charger light (re-zero if necessary.)

To read dosimeter by using charger light.

1. Place dosimeter on charging contact and PRESS DOWN GENTLY until charger light illuminates the scale.

CAUTION: If the dosimeter is pressed down too hard (too far), the reading will be altered.

2. To read any dosimeter of less than 0-5r range, turn voltage control all the way "up scale" then read dosimeter as above.

6. OPERATORS MAINTENANCE

GENERAL

A. TO OPEN CASE.

Loosen captive screw in bottom of charger and remove cover and lock assembly.

B. TO REPLACE BULB.

1. Open case.
2. Remove bulb.
3. Replace with spare bulb (No. 131 bulb or equivalent).

C. TO REPLACE BATTERY.

1. Open case.
2. Lift out battery.
3. Replace with $1\frac{1}{2}$ volt D cell NEDA type-13 or equivalent.

CAUTION: Orient battery as shown on battery orientation label on bottom of battery compartment and replace cover so that the rubber pad is over the battery.

D. CARE OF CHARGING CONTACT.

Always keep the protective cap on the charging contact when the charger is not in use. The clear plastic surfaces of the charging contact should be dry, clean and free of finger prints. A soft cloth free of grit, dirt, lint or moisture may be used to clean the plastic surfaces.

CAUTION: Do not use solvent or cleaning fluid to clean plastic (solvents can craze plastics).

STORAGE

- A. Remove the battery from chargers to be stored for more than 2 months.
- B. Store with case closed and protective cap on charging contact.

PREVENTIVE MAINTENANCE

- A. Clean battery contacts to bright metal with steel wool or equivalent.
- B. Check battery and bulb (replace as required).
- C. Check electrical operation.

7. TROUBLE SHOOTING

If instrument does not appear to operate normally, it may be for one of the following reasons:

ABNORMAL CONDITION	PROBABLE CAUSE	CORRECTIVE ACTION
Light weak or fails to go on when charging contact is depressed	Weak battery	Replace battery
	Dirty (corroded) battery or light switch springs contacts	Clean battery and light switch contacts with steel wool or equivalent, to bright metal finish.
	Loose light bulb	Tighten bulb in socket
Shadows appear on dosimeter scale	Burnt out bulb	Replace bulb.
	Dirt on charging contact	Clean charging contact
Fibre image unsteady (jittery movement of fibre image when rotation of coltage control	Dirt on either end of dosimeter	Clean dosimeter and eyepieces with clean dry lint-free cloth.
	Poor contact of dosimeter with outer aluminium sleeve of charging contact.	Keeping the dosimeter vertical, move dosimeter sideways to make the charging contact sleeve touch the inside wall of the dosimeter charging recess.
Light illuminated scale, but fibre image does not appear on scale with rotation of voltage control	Poor contact of dosimeter with outer aluminium sleeve of charging contact	Same as above.
	Dirt or moisture on charging end of dosimeter or charging contact	Clean or dry faulty part.
	Dirty light switch spring contacts	Clean switch contacts
	Faulty circuit component or connections	

8. If the charger does not operate after the preceding corrective action, expert attention may be needed.

CIVIL DEFENCE ORGANISATION

SOUTH AUSTRALIA

CIVIL DEFENCE - THE RADIAC SURVEY METER:

1. PURPOSE:

To measure radiation dose rate due to radioactive contamination on ground, equipment and vehicles, and to enable safe working time in a contaminated area to be calculated. Radiac Survey Meters will normally be used by reconnaissance parties of the Headquarters Service of the Civil Defence Corps, or may be used by Wardens at Post Warden level.

2. GENERAL DESCRIPTION:

(a) Introduction:

The Lionel V-715 is a portable, battery powered, transistorized survey meter using a plated steel, hermetically sealed ionization chamber as the detector. The chamber is mounted inside the case. The instrument and its accessories include a printed circuit board, ionization chamber, carrying strap and strap fastener. The case is watertight to withstand immersion.

(b) Ranges:

Four ranges are provided, 0-.5, 0-5, 0-50 and 0-500 r/hr. On the lowest range, the smallest division on the scale is .01 r/hr. Intensities higher than 500 r/hr., are indicated by the meter reading off scale. The instrument is not harmed by this.

(c) Controls:

Two controls are provided. The Range Switch is used to turn on the instrument, check its proper functioning, and select the required range. The Zero Control is used to adjust the meter to zero each time before use.

(d) Circuit Check:

The proper functioning of the measuring circuit including the battery may be checked by setting the range switch to Circuit Check and observing the meter reading. The limits of acceptable indication cover the top 30 percent of the scale. This is a reliable indication of the condition of the instrument.

(e) Batteries:

One 'D' size flashlight cell is used. The useful operating life is a minimum of 150 hours for continuous duty and somewhat longer for intermittent use.

(f) Physical Features:

The instrument is approximately 4½ inches wide, 8½ inches longer and 7 inches high including the handle and weighs 4 lbs. It is finished in bright yellow baked enamel. The panel is die cast zinc and the case drawn aluminium. The handle is also die cast zinc contoured to comfortably fit the hand.

3. INSTALLATION:

The instruments are shipped with the battery packed separately. To put the instrument into operation:-

- (i) Open the case by releasing the clamps at both ends and remove the lid assembly.
- (ii) Remove the battery from its package, taking care not to drop it.
- (iii) Place the 'D' cell in the battery holder positive end first. The housing is designed to assure correct polarity. The battery is held in place during use by pads in the bottom of the case.

4. OPERATION:

(a) Operating the Unit the First Time:

Turn the Range Switch to the Zero position, wait two minutes for the electrometer tube to warm up and adjust the Zero Control to bring the meter to zero.

Turn the range switch to the Check position. The meter should read within the red markings designated Circuit Check. If it does not, the battery may be dead or trouble may exist in the circuit. When the reading nears the bottom of the check band, the battery should be replaced. Operators maintenance should be limited to replacement of the battery.

(b) Reading the Instrument:

Turn the range switch to the X100, X10, X1 or X0.1 range as required and read the radiation intensity on the meter. The meter readings must be multiplied by the factor for the range being used.

Example:- A meter reading of 3.5 on the X0.1 range indicates a radiation field of 0.1×3.5 or 0.35 r/hr. The indicator lines on the sides and front of the unit indicate the centre line of the chamber.

5. OPERATOR'S MAINTENANCE:

(a) Battery Replacement:

The battery should be replaced when the Circuit Check setting on the range switch makes the meter read near the low end of the circuit check band.

Remove the instrument from the case by opening two catches. Remove battery from holder and install battery as outlined in Para. 3.

6. PREVENTIVE MAINTENANCE:

(a) Battery Life:

Caution:- Make certain the instrument is turned off whenever not in use. The OFF position places the index mark on the range switch perpendicular to the handle. The life of the battery is at least 150 hours under continuous use; for intermittent use the life is somewhat more.

(b) Storage:

The instruments are shipped in a packing container and should be left this way until ready to put into operation. This prevents the accumulation of dirt, moisture and radioactive contamination, which would interfere with the proper operation of the instrument. For storage purposes, it is best, wherever possible, to keep the instrument in a moderately cool area, as this will provide greater shelf life for the battery. The Instrument should not be stored with the battery installed.

(c) Battery Inspection:

Even under continuous use with leak-proof cells, it is advisable to check the batteries for leakage at least once a month.

-----oOo-----

